



LOGICAL INNOVATION FOR
PICK AND PLACE ROBOTICS

D5-800/D5-1100/D5-1300

The Codian Robotics D5-800/D5-1100/D5-1300 five-axis delta robots are ideal for high-speed top loading pick and place processes.

The chosen concept with 2 parallel axis results in the fastest, most robust delta pick & place robot with five axis in the world.

The parallel kinematics design is clean, fast and silent. The D5-800/D5-1100/D5-1300 delta pick and place robots are designed to perform with payloads up to 1,5 kg and have a working envelope of Ø 800/1100/1300 mm. The robots can be controlled by many different PLC and motion control systems. Combined with a vision system, they can also be used for random and/or mixed product flow picking.

- Open platform for servo motors and control systems
- Designed for applications up to 15G
- ISO mounted gripper plate
- Materials: carbon fibre, stainless steel, titanium, anodized aluminium, plastic
- Zero footprint
- Low maintenance, easy access to components



CODIAN
ROBOTICS

D5-800/D5-1100/D5-1300

THE NEW STANDARD FOR PICKING AND PLACING

SPECIFICATIONS

Kinematic structure:	delta type
Degrees of freedom:	5
Protection:	IP 65
Noise level:	< 68 dB(A)
Weight:	70 kg

PERFORMANCE

Rated working range:	Ø 800/1100/1300 x 250 mm (see drawing)
Payload (max.):	1,5 kg
Pick and Place actions	
D5-800:	max. 130 p/min
D5-1100:	max. 125 p/min
D5-1300:	max. 120 p/min
Position repeatability X,Y,Z:	± 0.1mm
Angular repeatability:	± 0.3°
Rotation axis:	angle unlimited limitation rotation axis torque 16 Nm
Tilt axis:	mechanically limited limitation tilt axis torque 12,5 Nm

WORKING AREA

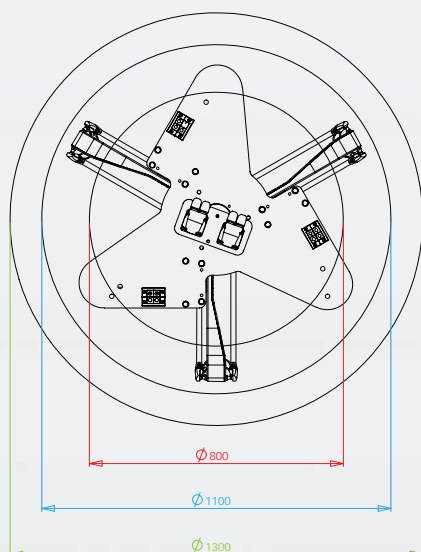

800 = D5-800
1100 = D5-1100
1300 = D5-1300

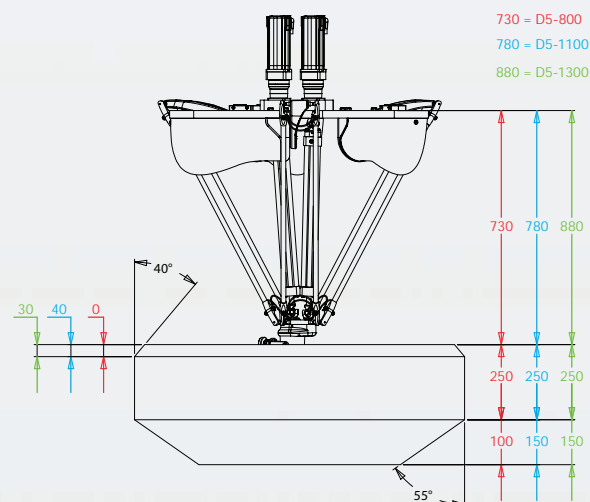

730 = D5-800
780 = D5-1100
880 = D5-1300

