

RCA2-SA2AC

RoboCylinder Mini Slider Type Motor Unit Coupling Type Actuator Width 20 mm 24 V Servo Motor Ball Screw Specification

■ Model Description **RCA2 – SA2AC – I – 5 –** – – – –

Series	Type	Encoder type	Motor type	Lead	Stroke	Compatible Controllers	Cable Length	Option
I: Incremental specification * Model number is "I" when used with simple absolute unit.	5: Servo Motor 5W	4: 4mm 2: 2mm 1: 1mm	25: 25mm 1 100: 100mm (every 25mm)	A3: ASEP	N: None P: 1m S: 3m M: 5m X <input type="checkbox"/> <input type="checkbox"/> : Length Designation	Following options Refer to below table		

*See page 13 for details on the model descriptions.

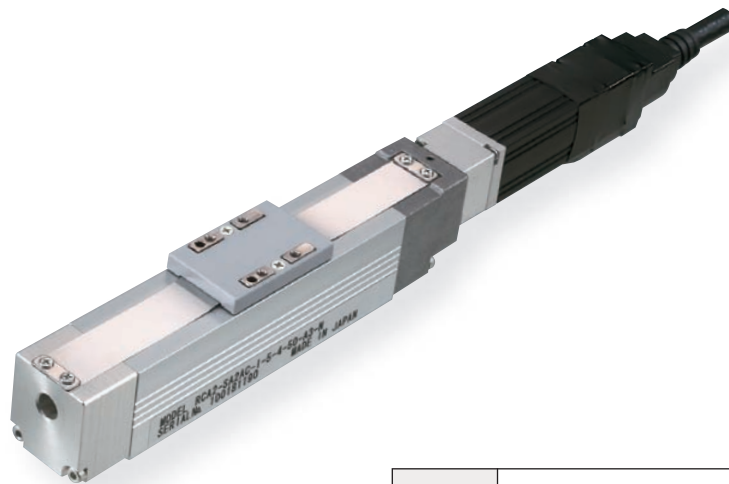

POINT
Notes on selection

(1) The payload is the value when operated at 0.3G acceleration. The acceleration upper limit is the value indicated above.
 (2) Take note that, since there is no brake, the slider may come down when the power is turned off if the actuator is used vertically.

Actuator Specification Table

Leads and Payloads

Model	Feed screw	Lead (mm)	Maximum payload		Positioning Repeatability (mm)	Stroke (mm)
			Horizontal (kg)	Vertical (kg)		
RCA2-SA2AC-I-5-4- <input type="checkbox"/> -A3- <input type="checkbox"/> - <input type="checkbox"/>	Ball screw	4	0.5	0.25	±0.02	25 to 100 (every 25mm)
RCA2-SA2AC-I-5-2- <input type="checkbox"/> -A3- <input type="checkbox"/> - <input type="checkbox"/>		2	1	0.5		
RCA2-SA2AC-I-5-1- <input type="checkbox"/> -A3- <input type="checkbox"/> - <input type="checkbox"/>		1	2	1		

Legend Stroke Cable length Option

Stroke and Maximum Speed

Lead	Stroke	Maximum Speed	
		25 (mm)	50 to 100 (mm)
Ball screw	4	180	200
	2	100	
	1	50	

(Unit = mm/s)

Cable length

Type	Cable symbol
Standard type (Robot cable)	P (1m)
	S (3m)
	M (5m)
Special length	X06 (6m) to X10 (10m)
	X11 (11m) to X15 (15m)
	X16 (16m) to X20 (20m)

*The standard cable for the RCA2 is the robot cable.

Actuator Specification

Item	Description
Drive System	Ball screw, φ4mm, rolled C10
Lost Motion	0.1mm or less
Base	Material: Aluminum, white alumite treated
Guide	Linear guide
Allowable Dynamic Moment	Ma: 0.22N-m Mb: 0.31N-m Mc: 0.28N-m
Allowable Overhang	40mm or less in Ma, Mb and Mc directions
Ambient Operating Temp., Humidity	0 to 40 °C, 85% RH or less (No condensation)
Service life	5000km

Options

Title	Option code	See page
Reversed-home specification	NM	–

Dimensional Drawings

CAD drawings can be downloaded from the website.

www.robocylinder.de



- *1 Connect the motor and encoder cables.
- *2 During home return, be careful to avoid interference from peripheral objects because the slider travels until the mechanical end.
- *3 The direction of the surface across flats varies depending on the product.

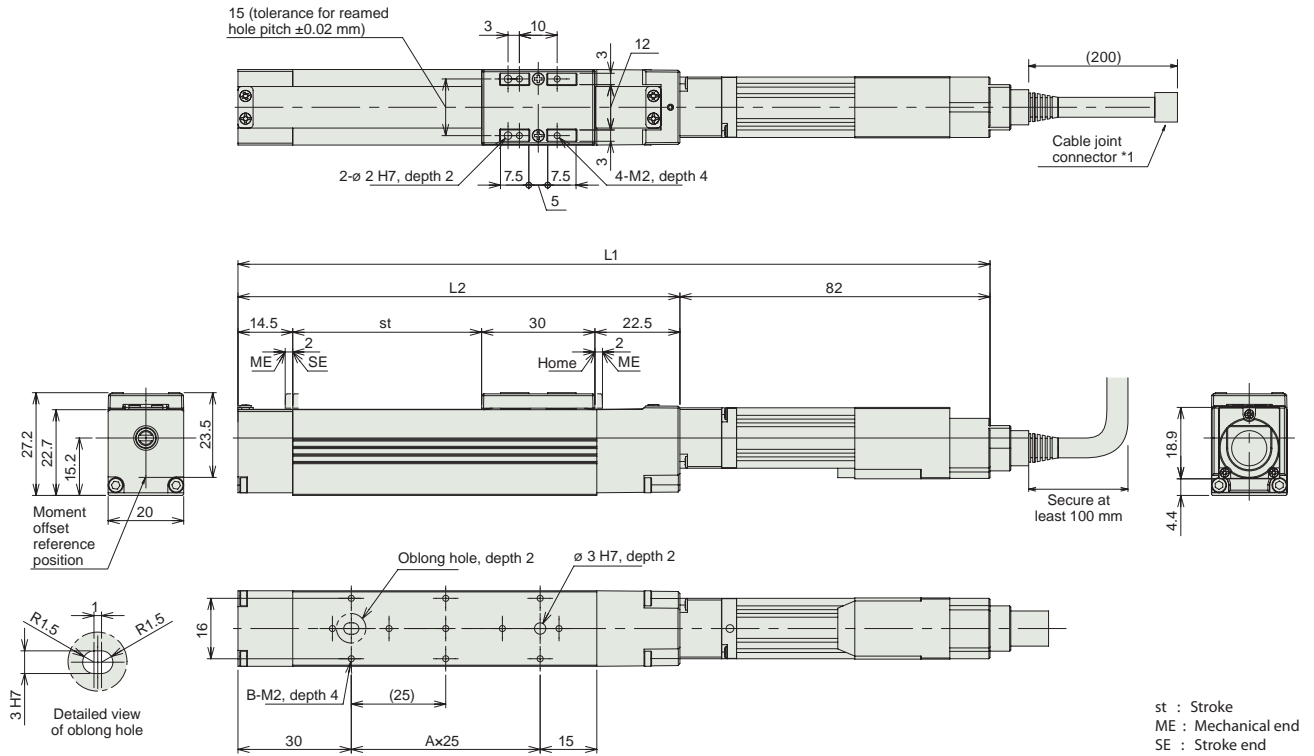

■ Dimensions and Weight by Stroke

Stroke	25	50	75	100
L1	174	199	224	249
L2	92	117	142	167
A	1	2	3	4
B	4	6	8	10
Mass (kg)	0.2	0.22	0.23	0.25

Compatible Controllers

RCA2 series actuators can be operated with the controllers indicated below. Select the type according to your intended application.

Title	External View	Model	Features	Maximum number of positioning points	Input power	Power-supply capacity	Reference Page
Solenoid valve type		ASEP-C-SSI-NP-2-0	Simple controller capable of operating with the same signal as the solenoid valve. Supports the use of both the single solenoid and the double solenoid types. Simple Absolute type makes the return to home unnecessary.	3 points	DC24V	(Standard) 1.5A rated 2.5A max.	→P123
Dust-proof solenoid valve type		PSEP-CW-SSI-NP-2-0					

RCA2-SA2AR

RoboCylinder Mini Slider Type Motor Unit Reverse-mounted Type Actuator Width 20 mm 24 V Servo Motor Ball Screw Specification

Model Description	RCA2	SA2AR	I	5					
	Series	Type	Encoder type	Motor type	Lead	Stroke	Compatible Controllers	Cable Length	Option
			I: Incremental specification * Model number is "I" when used with simple absolute unit.	5: Servo Motor 5W	4: 4mm 2: 2mm 1: 1mm	25: 25mm 1 100: 100mm (every 25mm)	A3: ASEP	N: None P: 1m S: 3m M: 5m X□□: Length Designation	Following options Refer to below table * Be sure to specify which side the motor is to be mounted (ML/MR)

*See page 13 for details on the model descriptions.



POINT
Notes on selection

(1) The payload is the value when operated at 0.3G acceleration. The acceleration upper limit is the value indicated above.

(2) Take note that, since there is no brake, the slider may come down when the power is turned off if the actuator is used vertically.

Actuator Specification Table

Leads and Payloads

Model	Feed screw	Lead (mm)	Maximum payload		Positioning Repeatability (mm)	Stroke (mm)
			Horizontal (kg)	Vertical (kg)		
RCA2-SA2AR-I-5-4-①-A3-②-③	Ball screw	4	0.5	0.25	±0.02	25 to 100 (every 25mm)
RCA2-SA2AR-I-5-2-①-A3-②-③		2	1	0.5		
RCA2-SA2AR-I-5-1-①-A3-②-③		1	2	1		

Legend ① Stroke ② Cable length ③ Option

Stroke and Maximum Speed

Lead	Stroke	Maximum Speed	
		25 (mm)	50 to 100 (mm)
Ball screw	4	180	200
	2	100	
	1	50	

(Unit = mm/s)

Cable length

Type	Cable symbol
Standard type (Robot cable)	P (1m)
	S (3m)
	M (5m)
Special length	X06 (6m) to X10 (10m)
	X11 (11m) to X15 (15m)
	X16 (16m) to X20 (20m)

* The standard cable for the RCA2 is the robot cable.

Actuator Specification

Item	Description
Drive System	Ball screw, φ4mm, rolled C10
Lost Motion	0.1mm or less
Base	Material: Aluminum, white alumite treated
Guide	Linear guide
Allowable Dynamic Moment	Ma: 0.22N-m Mb: 0.31N-m Mc: 0.28N-m
Allowable Overhang	40mm or less in Ma, Mb and Mc directions
Ambient Operating Temp., Humidity	0 to 40 °C, 85% RH or less (No condensation)
Service life	5000km

Options

Title	Option code	See page
Reversed-home specification	NM	—
Motor side mounted to the right	MR	—
Motor side mounted to the left	ML	—

Dimensional Drawings

CAD drawings can be downloaded from the website.

www.robocylinder.de



- *1 Connect the motor and encoder cables.
- *2 During home return, be careful to avoid interference from peripheral objects because the slider travels until the mechanical end.
- *3 The direction of the surface across flats varies depending on the product.

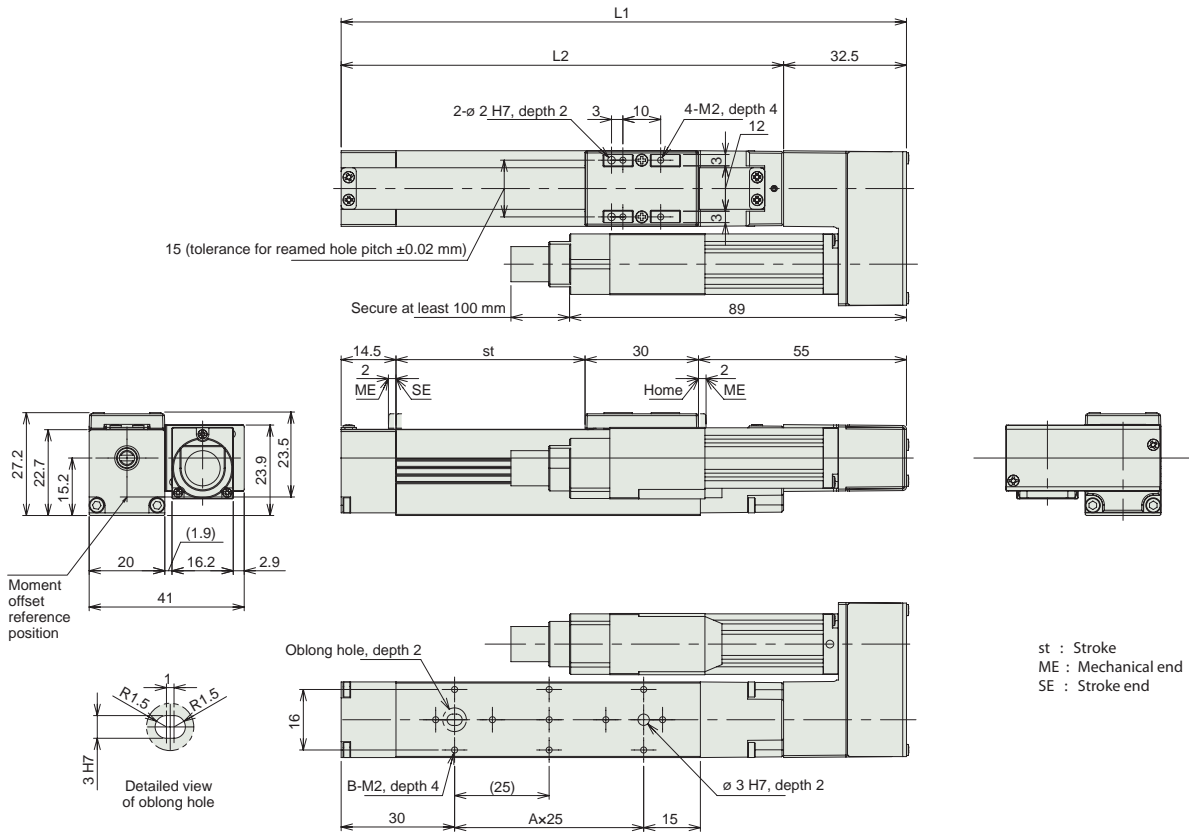

st : Stroke
ME : Mechanical end
SE : Stroke end

■ Dimensions and Weight by Stroke

Stroke	25	50	75	100
L1	124.5	149.5	174.5	199.5
L2	92	117	142	167
A	1	2	3	4
B	4	6	8	10
Mass (kg)	0.23	0.25	0.26	0.28

Compatible Controllers

RCA2 series actuators can be operated with the controllers indicated below. Select the type according to your intended application.

Title	External View	Model	Features	Maximum number of positioning points	Input power	Power-supply capacity	Reference Page
Solenoid valve type		ASEP-C-SSI-NP-2-0	Simple controller capable of operating with the same signal as the solenoid valve.	3 points	DC24V	(Standard) 1.5A rated 2.5A max.	→P123
Dust-proof solenoid valve type		PSEP-CW-SSI-NP-2-0	Supports the use of both the single solenoid and the double solenoid types. Simple Absolute type makes the return to home unnecessary.				

RCA2-RA2AC

RoboCylinder Mini Rod Type Motor Unit Coupling Type Actuator Width 18 mm 24 V Servo Motor Ball Screw Specification

■ Model Description									
RCA2	RA2AC	I	5						
Series	Type	Encoder type	Motor type	Lead	Stroke	Compatible Controllers	Cable Length	Option	
		I: Incremental specification * Model number is "I" when used with simple absolute unit.	5: Servo Motor 5W	4: 4mm 2: 2mm 1: 1mm	25: 25mm 1 100: 100mm (every 25mm)	A3: ASEP	N: None P: 1m S: 3m M: 5m X□□: Length Designation	Following options Refer to below table	

*See page 13 for details on the model descriptions.

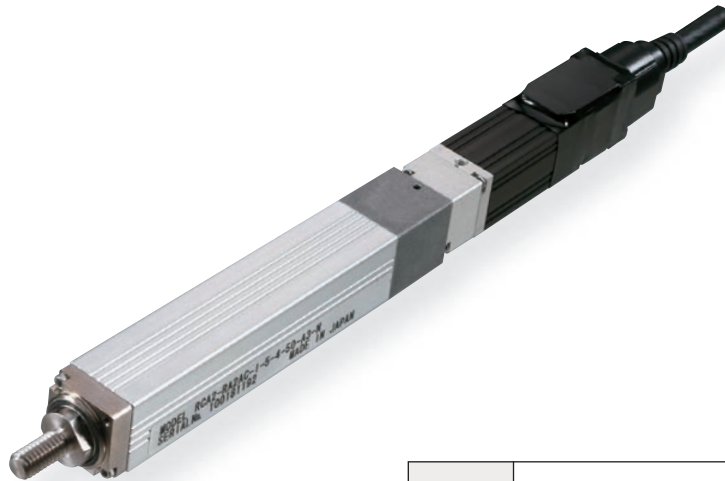

POINT

Notes on selection

(1) The payload is the value when operated at 0.3G acceleration. The acceleration upper limit is the value indicated above.

(2) Take note that, since there is no brake, the slider may come down when the power is turned off if the actuator is used vertically.

Actuator Specification Table

Leads and Payloads

Model	Feed screw	Lead (mm)	Maximum payload		Positioning Repeatability (mm)	Stroke (mm)
			Horizontal (kg)	Vertical (kg)		
RCA2-RA2AC-I-5-4-①-A3-②-③	Ball screw	4	0.5	0.25	±0.02	25 to 100 (every 25mm)
RCA2-RA2AC-I-5-2-①-A3-②-③		2	1	0.5		
RCA2-RA2AC-I-5-1-①-A3-②-③		1	2	1		

Legend ① Stroke ② Cable length ③ Option

Stroke and Maximum Speed

Lead	Stroke	Maximum Speed	
		25 (mm)	50 to 100 (mm)
Ball screw	4	180	200
	2	100	
	1	50	

(Unit = mm/s)

Cable length

Type	Cable symbol	
Standard type (Robot cable)	P (1m)	
	S (3m)	
	M (5m)	
Special length	X06 (6m) to X10 (10m)	
	X11 (11m) to X15 (15m)	
	X16 (16m) to X20 (20m)	

* The standard cable for the RCA2 is the robot cable.

Actuator Specification

Item	Description
Drive System	Ball screw, φ4mm, rolled C10
Lost Motion	0.1mm or less
Base	Material: Aluminum, white alumite treated
Non-rotating accuracy of rod	±3.0 deg
Ambient Operating Temp., Humidity	0 to 40 °C, 85% RH or less (No condensation)
Service life	5000km

Options

Title	Option code	See page	
Reversed-home specification	NM	-	

Dimensional Drawings

CAD drawings can be downloaded from the website.

www.robocylinder.de

2/3D CAD

- *1 Connect the motor and encoder cables.
- *2 During home return, be careful to avoid interference from peripheral objects because the slider travels until the mechanical end.
- *3 The direction of the surface across flats varies depending on the product.

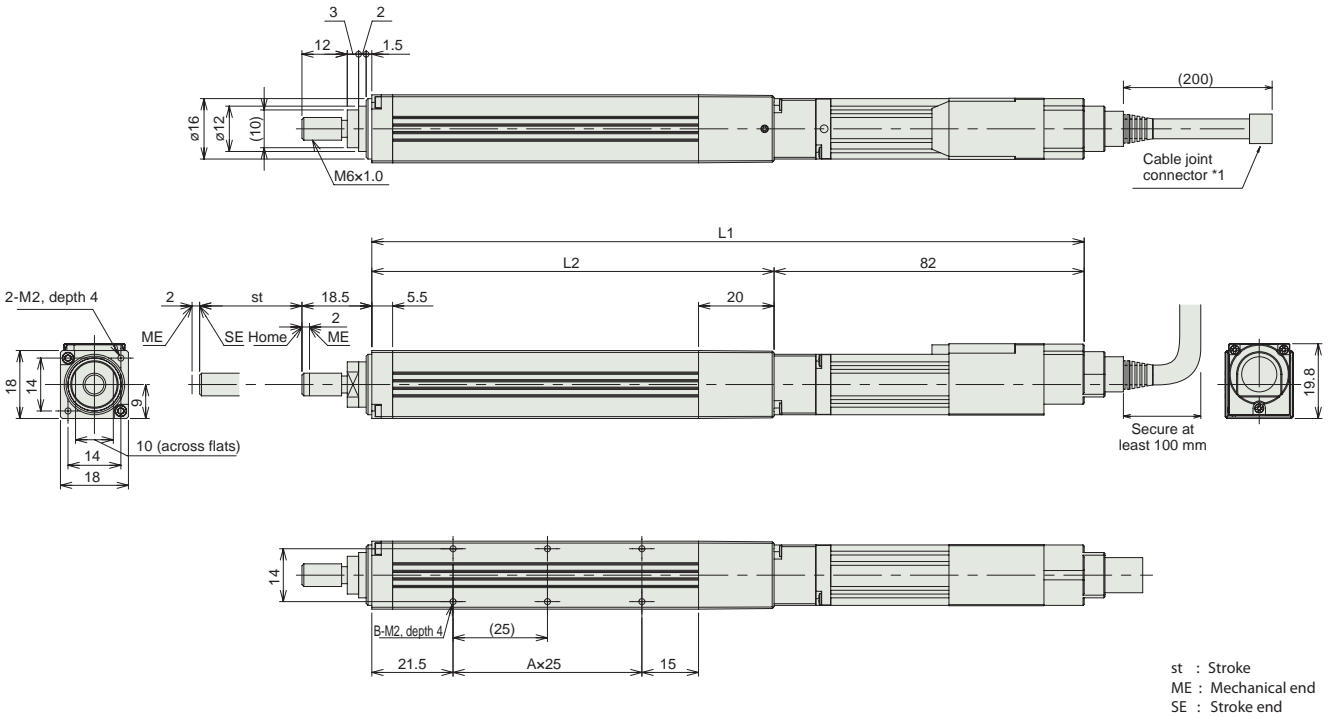



■ Dimensions and Weight by Stroke

Stroke	25	50	75	100
L1	163.5	188.5	213.5	238.5
L2	81.5	106.5	131.5	156.5
A	1	2	3	4
B	4	6	8	10
Mass (kg)	0.17	0.19	0.2	0.22

Compatible Controllers

RCA2 series actuators can be operated with the controllers indicated below. Select the type according to your intended application.

Title	External View	Model	Features	Maximum number of positioning points	Input power	Power-supply capacity	Reference Page
Solenoid valve type		ASEP-C-SSI-NP-2-0	Simple controller capable of operating with the same signal as the solenoid valve.	3 points	DC24V	(Standard) 1.5A rated 2.5A max.	→P123
Dust-proof solenoid valve type		PSEP-CW-SSI-NP-2-0	Supports the use of both the single solenoid and the double solenoid types. Simple Absolute type makes the return to home unnecessary.				

RCA2-RA2AR

RoboCylinder Mini Rod Type Motor Unit Reverse-mounted Type Actuator Width 18 mm 24 V Servo Motor Ball Screw Specification

Model Description		RCA2	RA2AR	I	5						
Series	Type	Encoder type	Motor type	Lead	Stroke	Compatible Controllers	Cable Length	Option			
		I: Incremental specification * Model number is "I" when used with simple absolute unit.	5: Servo Motor 5W	4: 4mm 2: 2mm 1: 1mm	25: 25mm 1 100: 100mm (every 25mm)	A3: ASEP	N: None P: 1m S: 3m M: 5m X□□: Length Designation	Following options Refer to below table * Be sure to specify which side the motor is to be mounted (ML/MR/MT)			

*See page 13 for details on the model descriptions.



POINT

Notes on selection

(1) The payload is the value when operated at 0.3G acceleration. The acceleration upper limit is the value indicated above.

(2) Take note that, since there is no brake, the slider may come down when the power is turned off if the actuator is used vertically.

Actuator Specification Table

Leads and Payloads

Model	Feed screw	Lead (mm)	Maximum payload		Positioning Repeatability (mm)	Stroke (mm)
			Horizontal (kg)	Vertical (kg)		
RCA2-RA2AR-I-5-4-①-A3-②-③	Ball screw	4	0.5	0.25	±0.02	25 to 100 (every 25mm)
RCA2-RA2AR-I-5-2-①-A3-②-③		2	1	0.5		
RCA2-RA2AR-I-5-1-①-A3-②-③		1	2	1		

Legend ① Stroke ② Cable length ③ Option

Stroke and Maximum Speed

Lead	Stroke	Maximum Speed	
		25 (mm)	50 to 100 (mm)
Ball screw	4	180	200
	2	100	
	1	50	

(Unit = mm/s)

Cable length

Type	Cable symbol	
Standard type (Robot cable)	P (1m)	
	S (3m)	
	M (5m)	
Special length	X06 (6m) to X10 (10m)	
	X11 (11m) to X15 (15m)	
	X16 (16m) to X20 (20m)	

* The standard cable for the RCA2 is the robot cable.

Actuator Specification

Item	Description
Drive System	Ball screw, φ4mm, rolled C10
Lost Motion	0.1mm or less
Base	Material: Aluminum, white alumite treated
Non-rotating accuracy of rod	±3.0 deg
Ambient Operating Temp., Humidity	0 to 40 °C, 85% RH or less (No condensation)
Service life	5000km

Options

Title	Option code	See page	
Reversed-home specification	NM	—	
Motor side mounted to the right	MR	—	
Motor side mounted to the left	ML	—	
Motor side mounted to the top	MT	—	

Dimensional Drawings

CAD drawings can be downloaded from the website. www.robocylinder.de



- *1 Connect the motor and encoder cables.
- *2 During home return, be careful to avoid interference from peripheral objects because the slider travels until the mechanical end.
- *3 The direction of the surface across flats varies depending on the product.

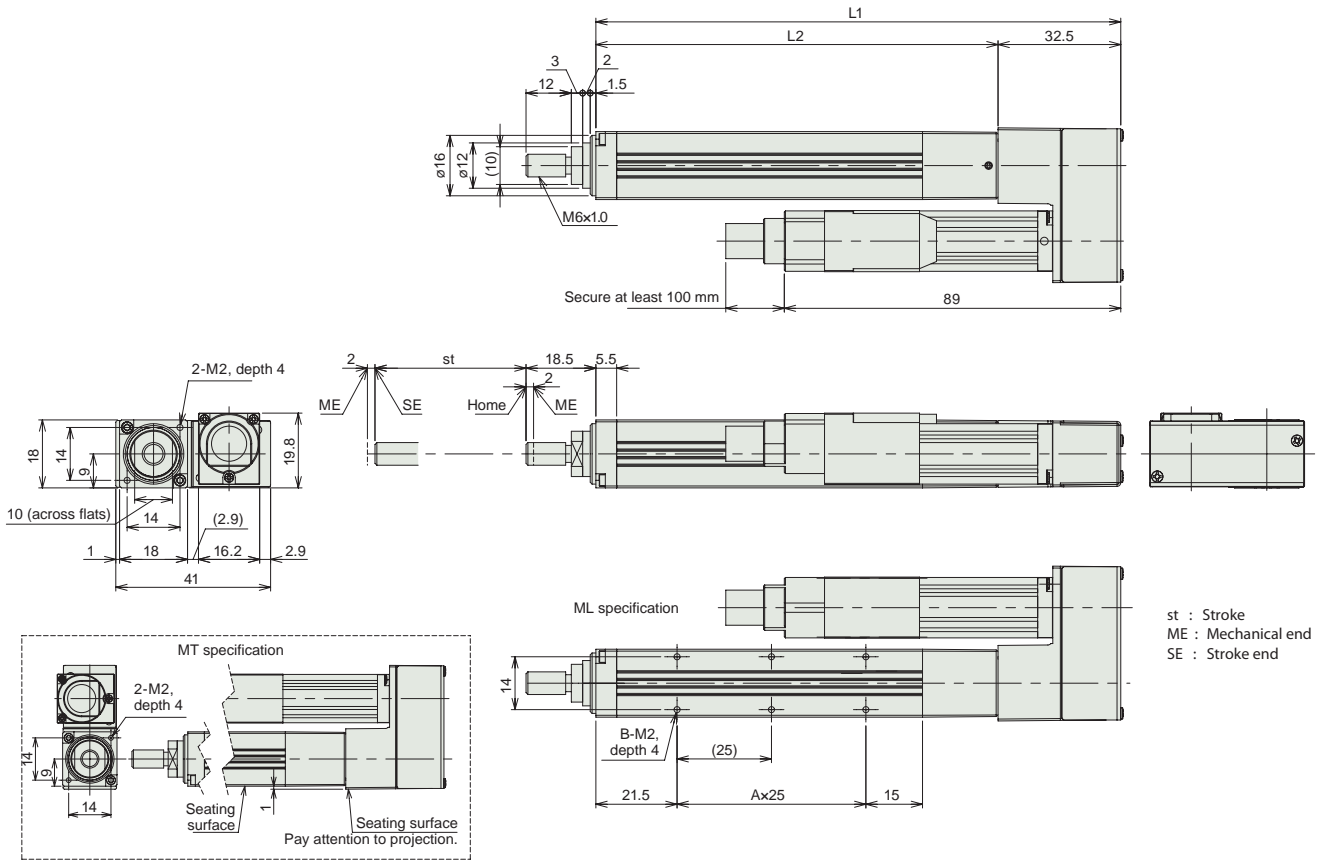

■ Dimensions and Weight by Stroke

Stroke	25	50	75	100
L1	114	139	164	189
L2	81.5	106.5	131.5	156.5
A	1	2	3	4
B	4	6	8	10
Mass (kg)	0.21	0.22	0.24	0.25

Compatible Controllers

RCA2 series actuators can be operated with the controllers indicated below. Select the type according to your intended application.

Title	External View	Model	Features	Maximum number of positioning points	Input power	Power-supply capacity	Reference Page
Solenoid valve type		ASEP-C-SSI-NP-2-0	Simple controller capable of operating with the same signal as the solenoid valve.	3 points	DC24V	(Standard) 1.5A rated 2.5A max.	→P123
Dust-proof solenoid valve type		PSEP-CW-SSI-NP-2-0	Supports the use of both the single solenoid and the double solenoid types. Simple Absolute type makes the return to home unnecessary.				