

Belt Driven Actuator **IFA**

IAI INTELLIGENT ACTUATOR

 Battery-less Absolute Encoder
No Battery,
No Maintenance, No Homing,
No Going Back to Incremental.



Ideal for long-distance transport between processes

High-speed Belt Driven Actuator

IFA

Long stroke

Low price

High payload

High-speed

Battery-less absolute encoder mounted

Easy maintenance

Simple dustproof

Max. payload
40kg

Max. 3200mm
Max. speed: 3000mm/s

Model	Stroke	Payload (horizontal)	Speed	Acceleration/ deceleration
IFA-SA□	2600mm	20kg	2000mm/s	2.0G
IFA-MA□	3200mm	40kg	3000mm/s	2.0G

*Max. value for each item

- Supports simple dustproofing with stainless steel sheet specification

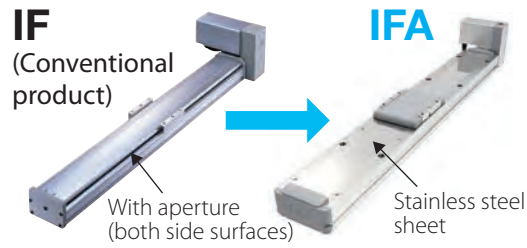

- Double slider specification available

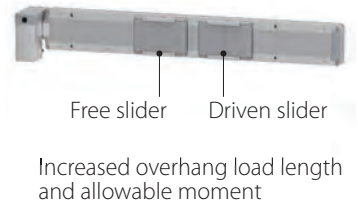

Example Loader/unloader for machines



Example Transport to circuit board inspection process

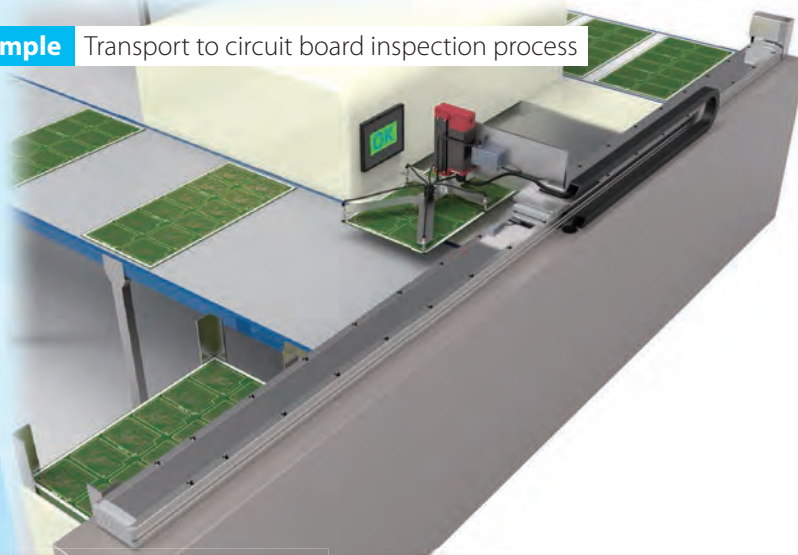

- Slider belt/drive belt tension adjustment is easy



Tension can be adjusted by twisting the bolts

- Regreasing and stainless steel sheet/belt replacement are possible without removing the mounting parts on the slider

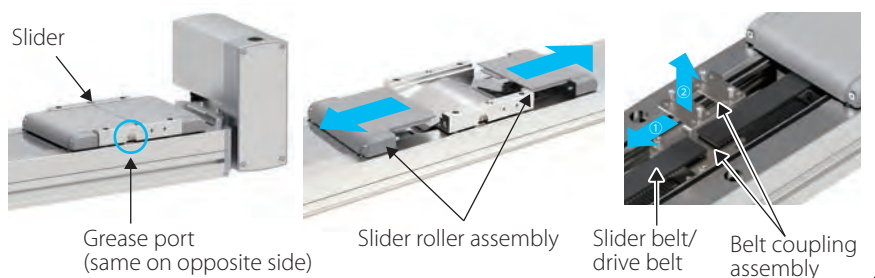

Product Lineup

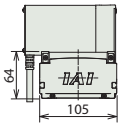
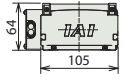
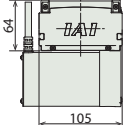
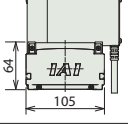
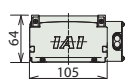
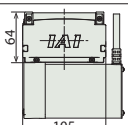
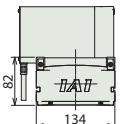
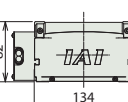
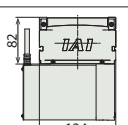
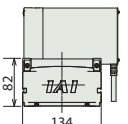
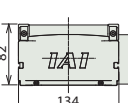
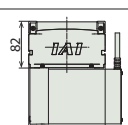
Type	Motor mounting direction	Body width *1	Motor output (W)	Lead (mm)	Positioning repeatability (mm)	Stroke (mm) *2	Max. speed (mm/s)	Horizontal max. payload (kg)	Specifications/drawings
IFA	SA1L		100	28 or equivalent	±0.04	200 to 1450	2000	20	P.7 to 12
						1500 ~ 2600		15	
	SA2L		100	28 or equivalent	±0.04	200 ~ 1450	2000	20	P.7 to 12
						1500 to 2600		15	
	SA3L		100	28 or equivalent	±0.04	200 ~ 1450	2000	20	P.7 to 12
						1500 ~ 2600		15	
	SA1R		100	28 or equivalent	±0.04	200 ~ 1450	2000	20	P.7 to 12
						1500 ~ 2600		15	
	SA2R		100	28 or equivalent	±0.04	200 ~ 1450	2000	20	P.7 to 12
						1500 ~ 2600		15	
	SA3R		100	28 or equivalent	±0.04	200 ~ 1450	2000	20	P.7 to 12
						1500 ~ 2600		15	
MA1L		134	200	42 or equivalent	±0.04	200 ~ 3200	3000	25	P.13 to 18
			400					40	P.19 to 24
MA2L		134	200	42 or equivalent	±0.04	200 ~ 3200	3000	25	P.13 to 18
			400					40	P.19 to 24
MA3L		134	200	42 or equivalent	±0.04	200 ~ 3200	3000	25	P.13 to 18
			400					40	P.19 to 24
MA1R		134	200	42 or equivalent	±0.04	200 ~ 3200	3000	25	P.13 to 18
			400					40	P.19 to 24
MA2R		134	200	42 or equivalent	±0.04	200 ~ 3200	3000	25	P.13 to 18
			400					40	P.19 to 24
MA3R		134	200	42 or equivalent	±0.04	200 ~ 3200	3000	25	P.13 to 18
			400					40	P.19 to 24

*1 When selecting the home limit switch option (L/LL), the width is 12mm larger. Please refer to the dimensions of each product page for more information.
 *2 Available at 50mm pitch intervals.

Model Specification Items

Series: IFA — Type: — Encoder: WA — Motor type: — Stroke: — Applicable controllers: — Cable length: — Option:

WA	Battery-less absolute
----	-----------------------

100	100W (SA□ type)
200	200W (MA□ type)
400	400W (MA□ type)

<IFA-SA□>

200	200mm
2600	2600mm

<IFA-MA□>

200	200mm
3200	3200mm

(50mm increments)

T2	SCON	N Without cable
	SSEL	
	XSEL-P/Q	
	XSEL-RA/SA	
T4	RCON	*Robot cable
	RSEL	

SA1L	Body width 105mm	Upward facing motor
SA2L		Horizontal motor
SA3L		Downward facing motor
SA1R		Upward facing motor opposite side
SA2R		Horizontal motor opposite side
SA3R		Downward facing motor opposite side
MA1L	Body width 134mm	Upward facing motor
MA2L		Horizontal motor
MA3L		Downward facing motor
MA1R		Upward facing motor opposite side
MA2R		Horizontal motor opposite side
MA3R		Downward facing motor opposite side

A6	Cable exit direction opposite side
AQ	AQ seal (equipped as standard) *1
CSM	Ceiling/side mounting specifications
EB	Hanging brackets *2
L	Home limit switch
LL	Home limit switch opposite side
NM	Non-motor end specification
W	Double slider specification
EU	Round cable joint connector

*1 Be sure to fill in the option field in the model specification items.
*2 IFA-MA□ type only.

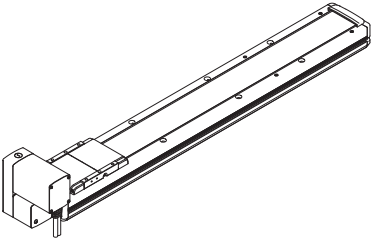
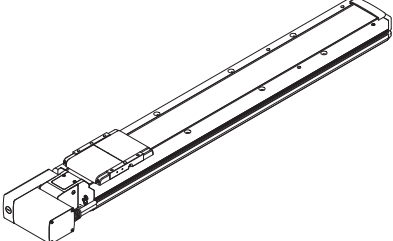
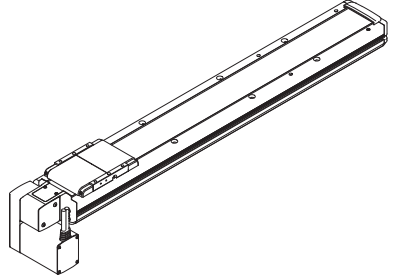
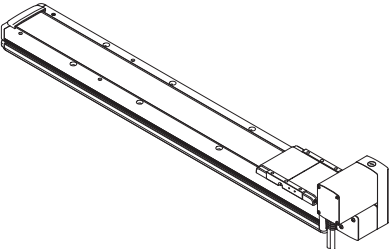
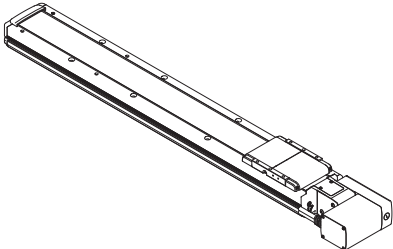
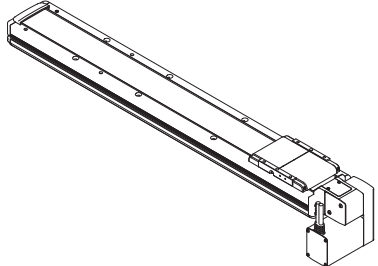

Type Description

The motor position can be selected from six types, as shown in the figure below. For horizontal motor and downward facing motor, the motor position is lower than the slider, with no concern about interference with workpieces.

<p>Upward facing motor</p> <p>SA1L/MA1L</p> 	<p>Horizontal motor</p> <p>SA2L/MA2L</p> 	<p>Downward facing motor</p> <p>SA3L/MA3L</p> 
<p>Upward facing motor opposite side</p> <p>SA1R/MA1R</p> 	<p>Horizontal motor opposite side</p> <p>SA2R/MA2R</p> 	<p>Downward facing motor opposite side</p> <p>SA3R/MA3R</p> 

Mounting Orientation

○: Can be mounted —: Cannot be mounted

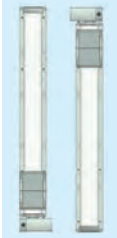
		Mounting orientation			
					
Series	Type	Horizontal mounting on flat surface	Horizontal mounting to side	Horizontal mounting suspended	Vertical mount
IFA	SA□	○	○ ^(*1) ○ ^(*2)	○ ^(*1) ○ ^(*2)	—
	MA□	○	○ ^(*1) ○ ^(*2)	○ ^(*1) ○ ^(*2)	—

- (*1) Installing the product horizontal to side or horizontal suspended may cause slack or misalignment in the stainless steel sheet. Continuing to use it this way could cause the stainless steel sheet to break. Please inspect it daily and adjust the sheet if any slack or misalignment is found.
- (*2) Be sure to select the "Ceiling/side mounted specifications (CSM)" option. Product with this option selected can also be mounted horizontally on flat surfaces.

Precautions for Installation

- Keep the body installation surface and workpiece mounting surface flatness within 0.05mm/m. Uneven flatness will increase the sliding resistance of the slider and may cause a malfunction.
- The body bottom base mounting surface and left side (viewed from the motor opposite side) are the reference surfaces for slider running accuracy. When running accuracy is required, mount with these surfaces as reference.
- Basically, use all through holes and secure all surfaces.

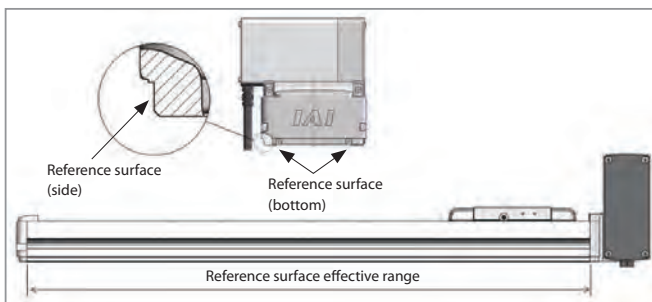

When mounting using the side reference surface, modify the installation surface as in the figure below.

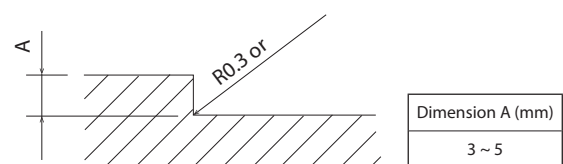

Overhang Load Length

This is the approximate offset at which the actuator can operate smoothly even when the workpiece or bracket is offset from the slider. Vibration or other factors could cause failure if the approximate length is greatly exceeded. The product should therefore be used within the approximate length.

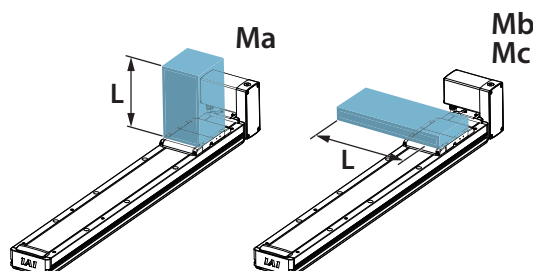

● Body mounting

This actuator has mounting through holes on the top surface.

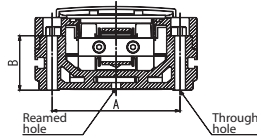
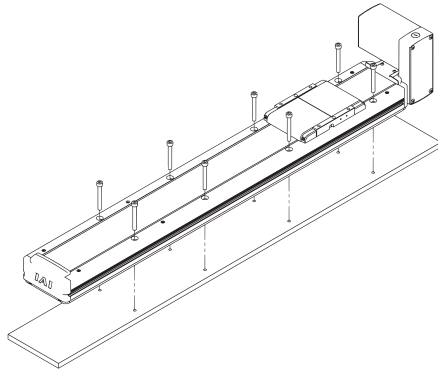

When using M8 bolts with the IFA-MA□ type, use the included dedicated washers for high-strength bolts in order to protect the base.

Type	Dimensions (mm)		Mounting hole diameter (mm)	Reamed hole
	A	B		
SA□	83	36	ø7 through, ø12 deep counterbored, depth 12	ø6H7 depth 6
MA□	109	48	ø9 through, ø16 deep counterbored, depth 12	ø8H7 depth 6

● Transported object mounting

Using the screw holes on the slider upper surface, mount the transported object.

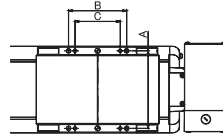
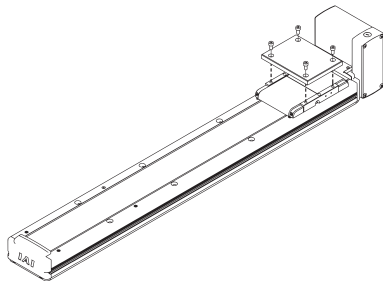

Type	Dimensions (mm)			Reamed hole	Mounting hole	
	A	B	C		Hole diameter (mm)	Number
SA1L/SA2L/SA3L	90	70	-	ø6H7 depth 10	M6 depth 15	4
SA1R/SA2R/SA3R					M6 depth 20	4
MA1L/MA2L/MA3L	120	-	70	ø8H7 depth 10	M6 depth 20	4
MA1R/MA2R/MA3R		90	-		M8 depth 20	4

<Caution>

For upward facing motor specifications (IFA-SA1□/MA1□), the motor part (motor cover) protrudes from the slider upper surface.

Be careful not to let the transported object interfere with the motor cover.

[Motor cover distance from slider center at mechanical end: A]

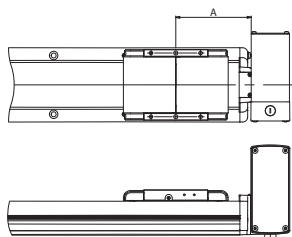

Type	A (mm)
SA1L/SA1R	96
MA1L/MA1R	124

● Connector box mounting and T-slot

There are M4 T-slots on the base surface for mounting the connector box, guide rails, etc. required for combination. Use as needed for sensor mounting, wiring fixing, etc.

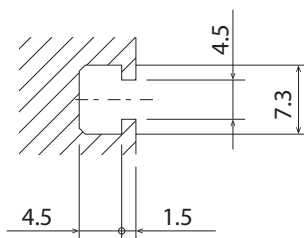

Square nuts are recommended for use with the T-slots, but ordinary hex nuts can also be used.

When mounting, be careful with the bolt length so that the bolt tip does not touch the T-slot bottom.

IFA-SA□□-100

Simple Dust-proof	Battery-less Absolute	Body Width 110 mm	100 W	Belt Type
-------------------	-----------------------	-------------------	-------	-----------

Model Specification Items

IFA	WA	100	Stroke	Applicable controllers	Cable length	Option
Series	Encoder type	Motor type	200 2600	T2 T4	N S M X□□	Please refer to the options table below.
Type	Battery-less absolute	100W / 100W	200mm 2600mm (every 50mm)	SCON SSEL XSEL-P/Q XSEL-RA/SA RCON RSEL	No 3m 5m Specified length	

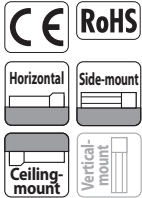

(Note) Photo above shows upward facing motor specification (SA1L).

POINT Selection Notes

- (1) Pay close attention to the mounting orientation. Please refer to P. 5 for details.
- (2) "Main Specifications" displays the payload's maximum value. Please refer to "Table of Payload by Speed/Acceleration" for more details.
- (3) Push-motion operation cannot be performed.
- (4) Estimated allowable duty ratio varies depending on load factor. Refer to P. 27 for details.
- (5) The center mass location of the attached object should be less than 1/2 of the overhang distance. Operating conditions should be moderated if abnormal vibration or noise is observed, even if the overhang distance and load moment are within allowable values.
- (6) Reference value of the overhang load length is under 450mm in the Ma, Mb, and Mc directions (for double slider specification, the actual slider span is min. [60mm]: 1200mm, max. [90mm]: 1350mm or below). Please refer to the explanation on P. 5 for the overhang load length.
- (7) When selecting the double slide specification, please refer to P. 26 for models to be ordered and precautions.

Cable Length

Type	Cable Code
Standard	S (3m)
	M (5m)
Specified length	X06(6m) ~ X10 (10m)
	X11 (11m) ~ X15 (15m)
	X16 (16m) ~ X20 (20m)
	X21 (21m) ~ X25 (25m)
	X26 (26m) ~ X30 (30m)

(Note) This is a robot cable.

Options * Please check the options reference pages to confirm each option.

Name	Model	Reference page
Cable exit direction opposite side	A6	25
AQ seal (equipped as standard) (Note 1)	AQ	25
Ceiling/side mounting specifications (Note 2)	CSM	25
Home limit switch	L	25
Home limit switch opposite side	LL	25
Non-motor end specification	NM	25
Double slider specification (Note 3)	W	25
Round cable joint connector with screw locking	EU	25

(Note 1) Be sure to fill in the option field in the model specification items.
 (Note 2) Also usable in horizontal mounting.
 (Note 3) When selecting the double slider specification (W), the payload, dimensions, and unit weight differ. Please refer to P. 8 and P. 12 for details.

Main Specifications

Item		Description	
Stroke		200 ~ 1450	1500 ~ 2600
Lead	Lead (mm)	28 or equivalent	28 or equivalent
Horizontal	Payload	Max. payload (kg) (*1)	20 15
		Max. speed (mm/s)	2000 2000
	Speed / acceleration / deceleration	Min. speed (mm/s)	1.71 1.71
		Rated acceleration/deceleration (G)	0.3 0.3
		Max. acceleration/deceleration (G)	2.0 2.0
Vertical	Payload	Max. payload (kg)	— —
		Max. speed (mm/s)	— —
	Speed / acceleration / deceleration	Min. speed (mm/s)	— —
		Rated acceleration/deceleration (G)	— —
		Max. acceleration/deceleration (G)	— —
Thrust	Rated thrust (N)	53.5 53.5	
Brake	Brake specification	— —	
	Brake holding force (kgf)	— —	
Stroke	Min. stroke (mm)	200 1500	
	Max. stroke (mm)	1450 2600	
	Stroke pitch (mm)	50 50	

(*1) When selecting the double slider specification (W), the max. payload is reduced. Please refer to the table below for more information.

Item	Description
Drive system	Timing belt, lead 28mm equivalent
Positioning repeatability	±0.04mm
Lost motion	0.1mm or less
Base	Material: Aluminum, white alumite treatment
Linear guide	Linear motion infinite circulating type
Static allowable moment (single slider specification)	Ma: 109N·m
	Mb: 156N·m
	Mc: 255N·m
Static allowable moment (double slider specification) (*2)	Ma: 744N·m
	Mb: 1060N·m
	Mc: 510N·m
Dynamic allowable moment (single slider specification) (*3)	Ma: 32.9N·m
	Mb: 47.0N·m
	Mc: 76.8N·m
Dynamic allowable moment (double slider specification) (*3)	Ma: Actual slider span min. [60mm] 182N·m, max. [90mm] 228N·m
	Mb: Actual slider span min. [60mm] 260N·m, max. [90mm] 325N·m
	Mc: Actual slider span min. [60mm] 125N·m, max. [90mm] 125N·m
Ambient operating temperature, humidity	0 ~ 40°C, 85% RH or less (Non-condensing)
Ingress protection	IP20
Vibration/shock resistance	4.9m/s ²
Compliant standards	CE marking, RoHS directive
Motor type	AC servo motor
Encoder type	Battery-less absolute
Number of encoder pulses	16384 pulse/rev

(*2) The figures are uniform regardless of slider span.

(*3) Based on the standard rated operation life of 10000km. Operation life varies according to operating and mounting conditions. Contact IAI to check the operation life.

Slider Type Moment Direction

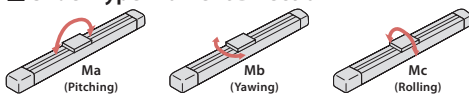

Table of Payload by Speed/Acceleration

The unit for payload is kg.

Lead (mm)	Max. speed (mm/s)	Stroke (mm)	Horizontal Acceleration (G)																	
			0.3	0.4	0.5	0.6	0.7	0.8	0.9	1.0	1.1	1.2	1.3	1.4	1.5	1.6	1.7	1.8	1.9	2.0
28	2000	200 ~ 1450	20	15.5	12.5	10	8.5	7.5	6.5	5.5	4.7	4.3	3.9	3.5	3.2	3	2.7	2.4	2.2	2
		1500 ~ 2600	15	15	12.5	10	8.5	7.5	6.5	5.5	4.7	4.3	3.9	3.5	3.2	3	2.7	2.4	2.2	2

(Note) The specs are the same even with different controller power supply voltages.

Table of Payload by Speed/Acceleration (double slider specification)

The unit for payload is kg. If blank, operation is not possible.

Lead (mm)	Max. speed (mm/s)	Nominal stroke (mm)	Horizontal Acceleration (G)																	
			0.3	0.4	0.5	0.6	0.7	0.8	0.9	1.0	1.1	1.2	1.3	1.4	1.5	1.6	1.7	1.8	1.9	2.0
28	2000	350 ~ 1450	18	13.5	10.5	8	6.5	5.5	4.5	3.5	2.7	2.3	1.9	1.5	1.2	1	0.7	0.4	0.2	
		1500 ~ 2600	13	13	10.5	8	6.5	5.5	4.5	3.5	2.7	2.3	1.9	1.5	1.2	1	0.7	0.4	0.2	

(Note) Nominal stroke is the stroke listed in the model name, not the actually operable stroke (effective stroke).

(Note) The specs are the same even with different controller power supply voltages.

Stroke and Max. Speed

200 ~ 2600 (every 50mm)
2000

(Unit: mm/s)

Dimensions

CAD drawings can be downloaded from our website.
www.intelligentactuator.de



IFA-SA1 (upward facing motor)

(Note) Connect the motor cable and encoder cable to the cable joint connector. Please refer to P. 30 for cable details.
 (Note) When the slider is returning to its home position, be careful of interference from surrounding objects, as it will travel until it reaches the M.E.
 (Note) Be aware that the product must be returned to IA1 in order to change the home direction.
 (Note) The figure below shows SA1L.

ST: Stroke
M.E: Mechanical end
S.E: Stroke end

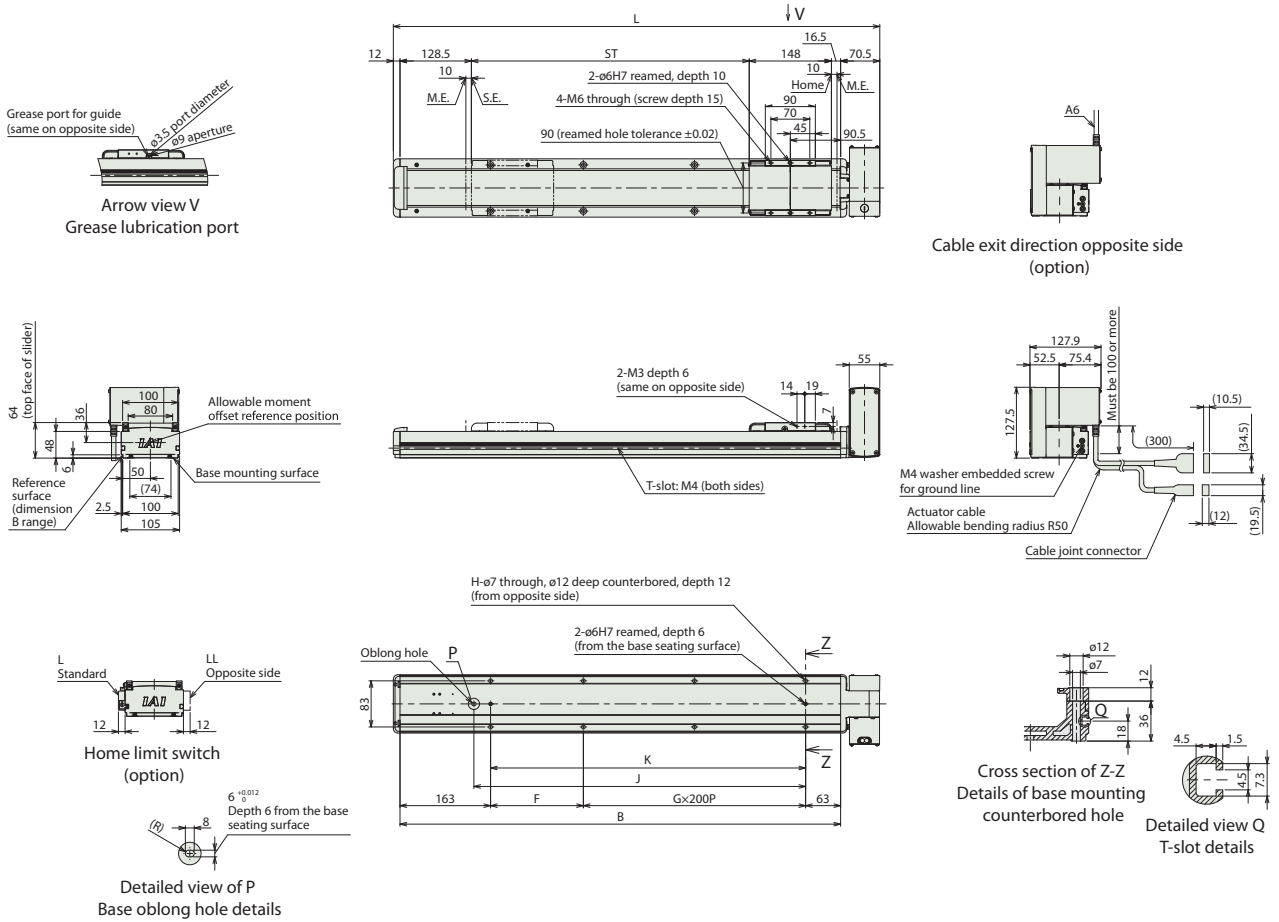

Dimensions by Stroke

Stroke	200	250	300	350	400	450	500	550	600	650	700	750	800	850	900	950	1000	1050	1100	1150	1200	1250	1300	1350	1400	
L	575.5	625.5	675.5	725.5	775.5	825.5	875.5	925.5	975.5	1025.5	1075.5	1125.5	1175.5	1225.5	1275.5	1325.5	1375.5	1425.5	1475.5	1525.5	1575.5	1625.5	1675.5	1725.5	1775.5	
B	493	543	593	643	693	743	793	843	893	943	993	1043	1093	1143	1193	1243	1293	1343	1393	1443	1493	1543	1593	1643	1693	
F	67	117	167	217	267	317	367	417	467	517	567	617	667	717	767	817	867	917	967	1017	1067	1117	1167	1217	1267	1317
G	1	1	1	1	2	2	2	2	3	3	3	3	4	4	4	4	5	5	5	5	6	6	6	6	7	
H	6	6	6	6	8	8	8	8	10	10	10	10	12	12	12	12	14	14	14	14	16	16	16	16	18	
J	297	347	397	447	497	547	597	647	697	747	797	847	897	947	997	1047	1097	1147	1197	1247	1297	1347	1397	1447	1497	
K	267	317	367	417	467	517	567	617	667	717	767	817	867	917	967	1017	1067	1117	1167	1217	1267	1317	1367	1417	1467	

Stroke	1450	1500	1550	1600	1650	1700	1750	1800	1850	1900	1950	2000	2050	2100	2150	2200	2250	2300	2350	2400	2450	2500	2550	2600
L	1825.5	1875.5	1925.5	1975.5	2025.5	2075.5	2125.5	2175.5	2225.5	2275.5	2325.5	2375.5	2425.5	2475.5	2525.5	2575.5	2625.5	2675.5	2725.5	2775.5	2825.5	2875.5	2925.5	2975.5
B	1743	1793	1843	1893	1943	1993	2043	2093	2143	2193	2243	2293	2343	2393	2443	2493	2543	2593	2643	2693	2743	2793	2843	2893
F	117	167	217	267	317	367	417	467	517	567	617	667	717	767	817	867	917	967	1017	1067	1117	1167	1217	1267
G	7	7	7	8	8	8	8	9	9	9	9	10	10	10	10	11	11	11	11	12	12	12	12	13
H	18	18	18	20	20	20	20	22	22	22	22	24	24	24	24	26	26	26	26	28	28	28	28	30
J	1547	1597	1647	1697	1747	1797	1847	1897	1947	1997	2047	2097	2147	2197	2247	2297	2347	2397	2447	2497	2547	2597	2647	2697
K	1517	1567	1617	1667	1717	1767	1817	1867	1917	1967	2017	2067	2117	2167	2217	2267	2317	2367	2417	2467	2517	2567	2617	2667

Mass by Stroke

Stroke	200	250	300	350	400	450	500	550	600	650	700	750	800	850	900	950	1000	1050	1100	1150	1200	1250	1300	1350	1400
Mass (kg)	6.0	6.3	6.6	7.0	7.3	7.6	7.9	8.3	8.6	8.9	9.2	9.5	9.9	10.2	10.5	10.8	11.2	11.5	11.8	12.1	12.4	12.8	13.1	13.4	13.7

Stroke	1450	1500	1550	1600	1650	1700	1750	1800	1850	1900	1950	2000	2050	2100	2150	2200	2250	2300	2350	2400	2450	2500	2550	2600
Mass (kg)	14.1	14.4	14.7	15.0	15.4	15.7	16.0	16.3	16.7	17.0	17.3	17.6	17.9	18.3	18.6	18.9	19.2	19.6	19.9	20.2	20.5	20.9	21.2	21.5

■ IFA-SA2 (horizontal motor)

(Note) Connect the motor cable and encoder cable to the cable joint connector. Please refer to P. 30 for cable details.
 (Note) When the slider is returning to its home position, be careful of interference from surrounding objects, as it will travel until it reaches the M.E.
 (Note) Be aware that the product must be returned to IAI in order to change the home direction.
 (Note) The figure below shows SA2L.

ST: Stroke
 M.E: Mechanical end
 S.E: Stroke end

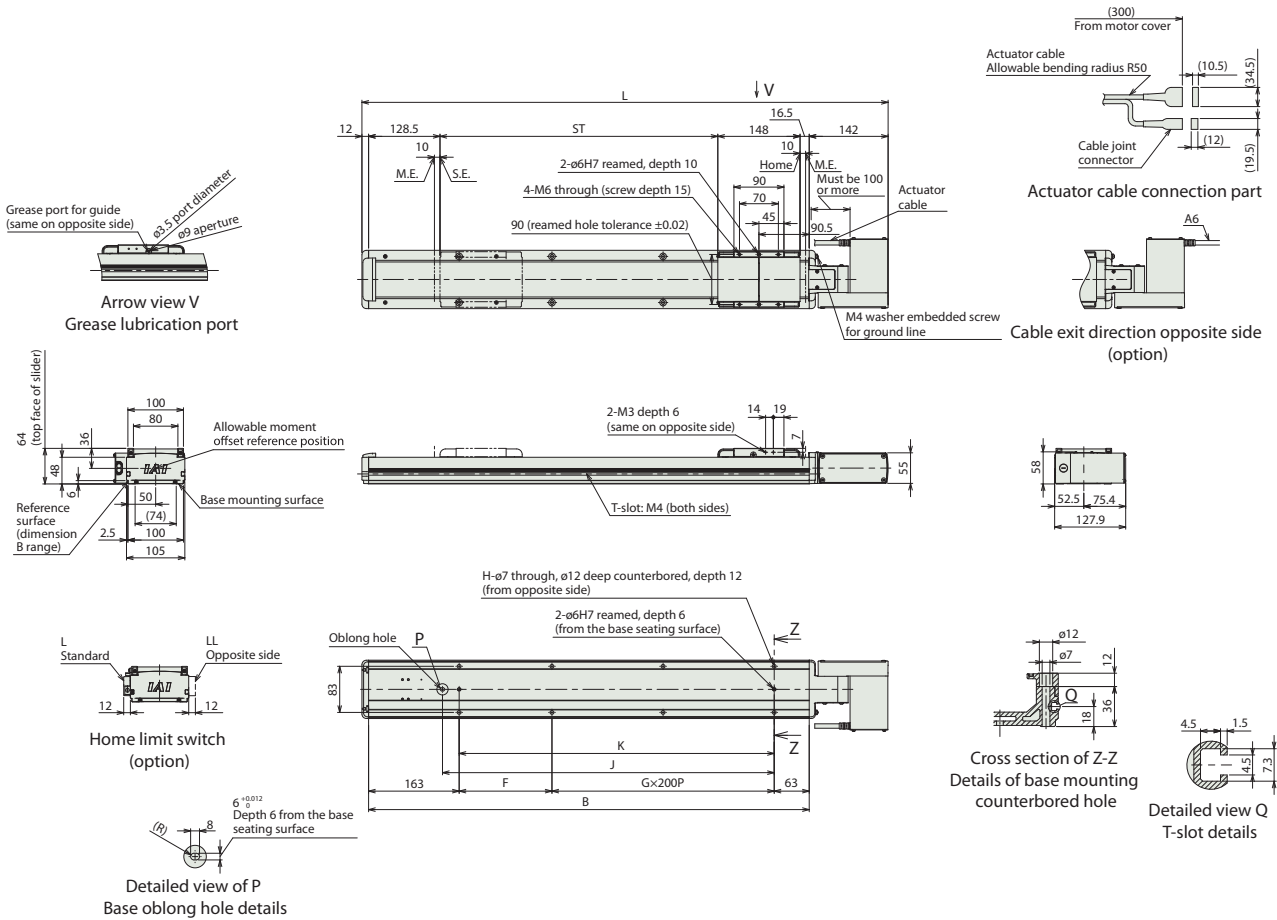

■ Dimensions by Stroke

Stroke	200	250	300	350	400	450	500	550	600	650	700	750	800	850	900	950	1000	1050	1100	1150	1200	1250	1300	1350	1400
L	647	697	747	797	847	897	947	997	1047	1097	1147	1197	1247	1297	1347	1397	1447	1497	1547	1597	1647	1697	1747	1797	1847
B	493	543	593	643	693	743	793	843	893	943	993	1043	1093	1143	1193	1243	1293	1343	1393	1443	1493	1543	1593	1643	1693
F	67	117	167	217	267	317	367	417	467	517	567	617	667	717	767	817	867	917	967	1017	1067	1117	1167	1217	1267
G	1	1	1	1	2	2	2	2	3	3	3	3	3	4	4	4	5	5	5	5	6	6	6	6	7
H	6	6	6	6	8	8	8	8	10	10	10	10	10	12	12	12	14	14	14	14	16	16	16	16	18
J	297	347	397	447	497	547	597	647	697	747	797	847	897	947	997	1047	1097	1147	1197	1247	1297	1347	1397	1447	1497
K	267	317	367	417	467	517	567	617	667	717	767	817	867	917	967	1017	1067	1117	1167	1217	1267	1317	1367	1417	1467

Stroke	1450	1500	1550	1600	1650	1700	1750	1800	1850	1900	1950	2000	2050	2100	2150	2200	2250	2300	2350	2400	2450	2500	2550	2600
L	1897	1947	1997	2047	2097	2147	2197	2247	2297	2347	2397	2447	2497	2547	2597	2647	2697	2747	2797	2847	2897	2947	2997	3047
B	1743	1793	1843	1893	1943	1993	2043	2093	2143	2193	2243	2293	2343	2393	2443	2493	2543	2593	2643	2693	2743	2793	2843	2893
F	117	167	217	267	317	367	417	467	517	567	617	667	717	767	817	867	917	967	1017	1067	1117	1167	1217	1267
G	7	7	7	8	8	8	8	9	9	9	9	10	10	10	10	11	11	11	11	11	12	12	12	13
H	18	18	18	20	20	20	20	22	22	22	22	24	24	24	24	26	26	26	26	26	28	28	28	30
J	1547	1597	1647	1697	1747	1797	1847	1897	1947	1997	2047	2097	2147	2197	2247	2297	2347	2397	2447	2497	2547	2597	2647	2697
K	1517	1567	1617	1667	1717	1767	1817	1867	1917	1967	2017	2067	2117	2167	2217	2267	2317	2367	2417	2467	2517	2567	2617	2667

■ Mass by Stroke

Stroke	200	250	300	350	400	450	500	550	600	650	700	750	800	850	900	950	1000	1050	1100	1150	1200	1250	1300	1350	1400
Mass (kg)	6.0	6.3	6.6	7.0	7.3	7.6	7.9	8.3	8.6	8.9	9.2	9.5	9.9	10.2	10.5	10.8	11.2	11.5	11.8	12.1	12.4	12.8	13.1	13.4	13.7

Stroke	1450	1500	1550	1600	1650	1700	1750	1800	1850	1900	1950	2000	2050	2100	2150	2200	2250	2300	2350	2400	2450	2500	2550	2600
Mass (kg)	14.1	14.4	14.7	15.0	15.4	15.7	16.0	16.3	16.7	17.0	17.3	17.6	17.9	18.3	18.6	18.9	19.2	19.6	19.9	20.2	20.5	20.9	21.2	21.5

IFA-SA3 (downward facing motor)

(Note) Connect the motor cable and encoder cable to the cable joint connector. Please refer to P. 30 for cable details.
 (Note) When the slider is returning to its home position, be careful of interference from surrounding objects, as it will travel until it reaches the M.E.
 (Note) Be aware that the product must be returned to IAI in order to change the home direction.
 (Note) The figure below shows SA3L.

ST: Stroke
 M.E.: Mechanical end
 S.E.: Stroke end

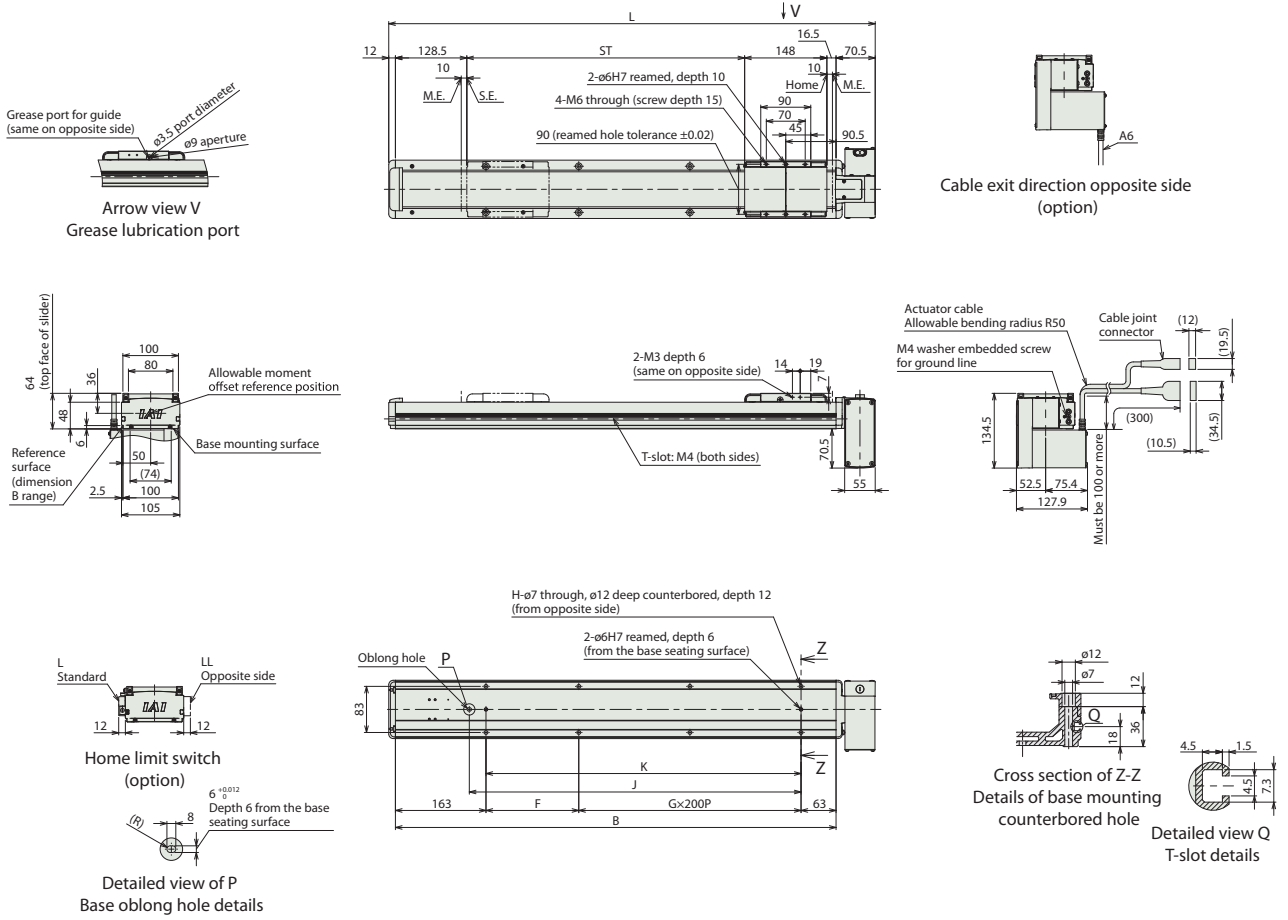

Dimensions by Stroke

Stroke	200	250	300	350	400	450	500	550	600	650	700	750	800	850	900	950	1000	1050	1100	1150	1200	1250	1300	1350	1400	
L	575.5	625.5	675.5	725.5	775.5	825.5	875.5	925.5	975.5	1025.5	1075.5	1125.5	1175.5	1225.5	1275.5	1325.5	1375.5	1425.5	1475.5	1525.5	1575.5	1625.5	1675.5	1725.5	1775.5	
B	493	543	593	643	693	743	793	843	893	943	993	1043	1093	1143	1193	1243	1293	1343	1393	1443	1493	1543	1593	1643	1693	
F	67	117	167	217	267	317	367	417	467	517	567	617	667	717	767	817	867	917	967	1017	1067	1117	1167	1217	1267	1317
G	1	1	1	1	2	2	2	2	3	3	3	3	4	4	4	4	5	5	5	5	6	6	6	6	7	
H	6	6	6	6	8	8	8	8	10	10	10	10	12	12	12	12	14	14	14	14	16	16	16	16	18	
J	297	347	397	447	497	547	597	647	697	747	797	847	897	947	997	1047	1097	1147	1197	1247	1297	1347	1397	1447	1497	
K	267	317	367	417	467	517	567	617	667	717	767	817	867	917	967	1017	1067	1117	1167	1217	1267	1317	1367	1417	1467	

Stroke	1450	1500	1550	1600	1650	1700	1750	1800	1850	1900	1950	2000	2050	2100	2150	2200	2250	2300	2350	2400	2450	2500	2550	2600
L	1825.5	1875.5	1925.5	1975.5	2025.5	2075.5	2125.5	2175.5	2225.5	2275.5	2325.5	2375.5	2425.5	2475.5	2525.5	2575.5	2625.5	2675.5	2725.5	2775.5	2825.5	2875.5	2925.5	2975.5
B	1743	1793	1843	1893	1943	1993	2043	2093	2143	2193	2243	2293	2343	2393	2443	2493	2543	2593	2643	2693	2743	2793	2843	2893
F	117	167	217	267	317	367	417	467	517	567	617	667	717	767	817	867	917	967	1017	1067	1117	1167	1217	1267
G	7	7	7	8	8	8	8	9	9	9	9	10	10	10	10	11	11	11	11	12	12	12	12	13
H	18	18	18	20	20	20	20	22	22	22	22	24	24	24	24	26	26	26	26	28	28	28	28	30
J	1547	1597	1647	1697	1747	1797	1847	1897	1947	1997	2047	2097	2147	2197	2247	2297	2347	2397	2447	2497	2547	2597	2647	2697
K	1517	1567	1617	1667	1717	1767	1817	1867	1917	1967	2017	2067	2117	2167	2217	2267	2317	2367	2417	2467	2517	2567	2617	2667

Mass by Stroke

Stroke	200	250	300	350	400	450	500	550	600	650	700	750	800	850	900	950	1000	1050	1100	1150	1200	1250	1300	1350	1400
Mass (kg)	6.0	6.3	6.6	7.0	7.3	7.6	7.9	8.3	8.6	8.9	9.2	9.5	9.9	10.2	10.5	10.8	11.2	11.5	11.8	12.1	12.4	12.8	13.1	13.4	13.7

Stroke	1450	1500	1550	1600	1650	1700	1750	1800	1850	1900	1950	2000	2050	2100	2150	2200	2250	2300	2350	2400	2450	2500	2550	2600
Mass (kg)	14.1	14.4	14.7	15.0	15.4	15.7	16.0	16.3	16.7	17.0	17.3	17.6	17.9	18.3	18.6	18.9	19.2	19.6	19.9	20.2	20.5	20.9	21.2	21.5

Dimension for double slider specification

(Note) Connect the motor cable and encoder cable to the cable joint connector. Please refer to P. 30 for cable details.
 (Note) When the slider is returning to its home position, be careful of interference from surrounding objects, as it will travel until it reaches the M.E.
 (Note) Be aware that the product must be returned to IA in order to change the home direction.
 (Note) The figure below shows SA1L.
 (Note) The figure below shows dimensions at minimum actual slider span.

CAD drawings can be downloaded from our website.
www.intelligentactor.de



ST: Stroke
 M.E: Mechanical end
 S.E: Stroke end

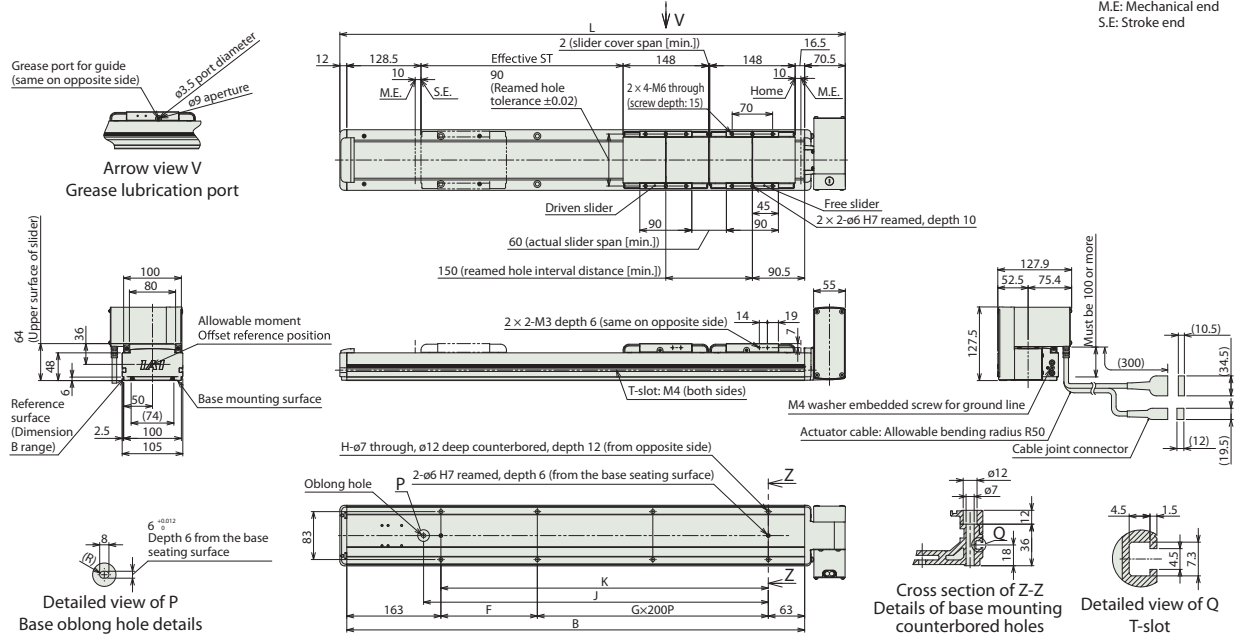

Dimensions by Stroke

Nominal stroke	350	400	450	500	550	600	650	700	750	800	850	900	950	1000	1050	1100	1150	1200	1250	1300	1350	1400	1450
Effective stroke	200	250	300	350	400	450	500	550	600	650	700	750	800	850	900	950	1000	1050	1100	1150	1200	1250	1300
Actual slider span minimum [60mm]	—	220	270	320	370	420	470	520	570	620	670	720	770	820	870	920	970	1020	1070	1120	1170	1220	1270
Actual slider span maximum [90mm]	—	—	—	—	—	—	—	—	—	—	—	—	—	—	—	—	—	—	—	—	—	—	—
L	725.5	775.5	825.5	875.5	925.5	975.5	1025.5	1075.5	1125.5	1175.5	1225.5	1275.5	1325.5	1375.5	1425.5	1475.5	1525.5	1575.5	1625.5	1675.5	1725.5	1775.5	1825.5
B	643	693	743	793	843	893	943	993	1043	1093	1143	1193	1243	1293	1343	1393	1443	1493	1543	1593	1643	1693	1743
F	217	67	117	167	217	67	117	167	217	67	117	167	217	67	117	167	217	67	117	167	217	67	117
G	1	2	2	2	2	3	3	3	3	4	4	4	4	5	5	5	5	6	6	6	6	7	7
H	6	8	8	8	8	10	10	10	10	12	12	12	12	14	14	14	14	16	16	16	16	18	18
J	447	497	547	597	647	697	747	797	847	897	947	997	1047	1097	1147	1197	1247	1297	1347	1397	1447	1497	1547
K	417	467	517	567	617	667	717	767	817	867	917	967	1017	1067	1117	1167	1217	1267	1317	1367	1417	1467	1517

Nominal stroke	1500	1550	1600	1650	1700	1750	1800	1850	1900	1950	2000	2050	2100	2150	2200	2250	2300	2350	2400	2450	2500	2550	2600
Effective stroke	1350	1400	1450	1500	1550	1600	1650	1700	1750	1800	1850	1900	1950	2000	2050	2100	2150	2200	2250	2300	2350	2400	2450
Actual slider span minimum [60mm]	1320	1370	1420	1470	1520	1570	1620	1670	1720	1770	1820	1870	1920	1970	2020	2070	2120	2170	2220	2270	2320	2370	2420
Actual slider span maximum [90mm]	—	—	—	—	—	—	—	—	—	—	—	—	—	—	—	—	—	—	—	—	—	—	—
L	1875.5	1925.5	1975.5	2025.5	2075.5	2125.5	2175.5	2225.5	2275.5	2325.5	2375.5	2425.5	2475.5	2525.5	2575.5	2625.5	2675.5	2725.5	2775.5	2825.5	2875.5	2925.5	2975.5
B	1793	1843	1893	1943	1993	2043	2093	2143	2193	2243	2293	2343	2393	2443	2493	2543	2593	2643	2693	2743	2793	2843	2893
F	167	217	67	117	167	217	67	117	167	217	67	117	167	217	67	117	167	217	67	117	167	217	67
G	7	7	8	8	8	8	9	9	9	9	10	10	10	11	11	11	11	11	12	12	12	12	13
H	18	18	20	20	20	20	22	22	22	22	24	24	24	24	26	26	26	26	28	28	28	28	30
J	1597	1647	1697	1747	1797	1847	1897	1947	1997	2047	2097	2147	2197	2247	2297	2347	2397	2447	2497	2547	2597	2647	2697
K	1567	1617	1667	1717	1767	1817	1867	1917	1967	2017	2067	2117	2167	2217	2267	2317	2367	2417	2467	2517	2567	2617	2667

(Note) Nominal stroke: Stroke listed in the model name; effective stroke: actually operable stroke

Mass by Stroke

Nominal stroke	350	400	450	500	550	600	650	700	750	800	850	900	950	1000	1050	1100	1150	1200	1250	1300	1350	1400	1450
Effective stroke	200	250	300	350	400	450	500	550	600	650	700	750	800	850	900	950	1000	1050	1100	1150	1200	1250	1300
Actual slider span minimum [60mm]	—	220	270	320	370	420	470	520	570	620	670	720	770	820	870	920	970	1020	1070	1120	1170	1220	1270
Actual slider span maximum [90mm]	—	—	—	—	—	—	—	—	—	—	—	—	—	—	—	—	—	—	—	—	—	—	—
Mass (kg)	7.7	8.0	8.3	8.6	9.0	9.3	9.6	9.9	10.2	10.6	10.9	11.2	11.5	11.9	12.2	12.5	12.8	13.1	13.5	13.8	14.1	14.4	14.8

Nominal stroke	1500	1550	1600	1650	1700	1750	1800	1850	1900	1950	2000	2050	2100	2150	2200	2250	2300	2350	2400	2450	2500	2550	2600
Effective stroke	1350	1400	1450	1500	1550	1600	1650	1700	1750	1800	1850	1900	1950	2000	2050	2100	2150	2200	2250	2300	2350	2400	2450
Actual slider span minimum [60mm]	1320	1370	1420	1470	1520	1570	1620	1670	1720	1770	1820	1870	1920	1970	2020	2070	2120	2170	2220	2270	2320	2370	2420
Actual slider span maximum [90mm]	—	—	—	—	—	—	—	—	—	—	—	—	—	—	—	—	—	—	—	—	—	—	—
Mass (kg)	15.1	15.4	15.7	16.1	16.4	16.7	17.0	17.4	17.7	18.0	18.3	18.6	19.0	19.3	19.6	19.9	20.3	20.6	20.9	21.2	21.6	21.9	22.2

(Note) The above mass values are for double slider specification. It is the sum of single slider specification's mass and free slider's mass (0.7kg)

Applicable Controllers

The actuator on this page can be operated with the controllers below. Select a type suited to the application.

Name	External view	Max. number of connectable axes	Power supply voltage	Control method														Max. number of positioning points	Reference page	
				Positioner	Pulse-train	Program	Network option *													
				DV	CC	CIE	PR	CN	ML	ML3	EC	EP	PRT	SSN	ECM					
RCON		16	DC24V Single phase 230VAC Three-phase 230VAC	—	—	—	●	●	●	●	—	—	—	●	●	●	—	●	128	Please see the dedicated catalog or manual.
RSEL		8		—	—	●	●	●	●	—	—	—	●	●	●	—	—	●	36000	
SCON-CB/CGB		1	Single phase AC 115V/230V	●	●	—	●	●	●	●	—	—	●	●	●	—	●	512 (768 for network specification)		
SSEL-CS		2		●	—	●	●	●	●	—	—	—	●	—	—	—	—	●	20000	
XSEL-P/Q		6	Single phase 230VAC	—	—	●	●	—	●	—	—	—	—	●	—	—	—	●	20000	
XSEL-RA/SA		8	Three-phase 230VAC	—	—	●	●	●	●	—	—	—	—	●	●	—	—	●	55000 (varies by type)	

* Network abbreviations: DV - DeviceNet | CC - CC-Link | CIE - CC-Link IE | PR - Profibus-DP | CN - CompoNet | ML - Mechatrolink | ML3 - Mechatrolink-III | EC - EtherCAT | EP - Ethernet/IP | PRT - Profinet-IO | SSN - SSCNET III/H | ECM - EtherCAT Motion

IFA-MA□□-200

Simple Dust-proof	Battery-less Absolute	Body Width 130 mm	200 W	Belt Type
-------------------	-----------------------	-------------------	-------	-----------

IFA		WA		200		Stroke		Applicable controllers		Cable length		Option
Series	Type	Encoder type	Motor type	200	200mm	T2	SCON	N	No	Please refer to the options table below.		
MA1L	Upward facing motor	WA	200	3200	3200mm (every 50mm)	SSEL	XSEL-P/Q	S	3m			
MA2L	Horizontal motor		200W			XSEL-RA/SA	M	5m	X□□	Specified length		
MA3L	Downward facing motor					T4	RCON					
MA1R	Upward facing motor opposite side						RSEL					
MA2R	Horizontal motor opposite side											
MA3R	Downward facing motor opposite side											

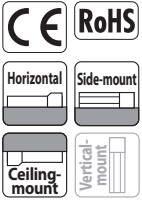

(Note) Photo above shows upward facing motor specification (MA1L).

POINT
Selection Notes

- (1) Pay close attention to the mounting orientation. Please refer to P. 5 for details.
- (2) "Main Specifications" displays the payload's maximum value. Please refer to "Table of Payload by Speed/Acceleration" for more details.
- (3) Push-motion operation cannot be performed.
- (4) Estimated allowable duty ratio varies depending on load factor. Refer to P. 27 for details.
- (5) The center mass location of the attached object should be less than 1/2 of the overhang distance. Operating conditions should be moderated if abnormal vibration or noise is observed, even if the overhang distance and load moment are within allowable values.
- (6) Reference value of the overhang load length is under 600mm in the Ma, Mb, and Mc directions (for double slider specification, the actual slider span is min. [80mm]: 1600mm, max. [120mm]: 1800mm or below). Please refer to the explanation on P. 5 for the overhang load length.
- (7) When selecting the double slide specification, please refer to P. 26 for models to be ordered and precautions.

Cable Length	
Type	Cable Code
Standard	S (3m)
	M (5m)
Specified length	X06(6m) ~ X10 (10m)
	X11 (11m) ~ X15 (15m)
	X16 (16m) ~ X20 (20m)
	X21 (21m) ~ X25 (25m)
	X26(26m) ~ X30 (30m)

(Note) This is a robot cable.

Options * Please check the options reference pages to confirm each option.		
Name	Model	Reference page
Cable exit direction opposite side	A6	25
AQ seal (equipped as standard) (Note 1)	AQ	25
Ceiling/side mounting specifications (Note 2)	CSM	25
Hanging brackets (Note 3)	EB	25
Home limit switch (Note 3)	L	25
Home limit switch opposite side (Note 3)	LL	25
Non-motor end specification	NM	25
Double slider specification (Note 4)	W	25
Round cable joint connector with screw locking	EU	25

- (Note 1) Be sure to fill in the option field in the model specification items.
 (Note 2) Also usable in horizontal mounting.
 (Note 3) Due to mutual interference, the hanging brackets (EB) and home limit switch (L/LL) cannot be used together.
 (Note 4) When selecting the double slider specification (W), the payload, dimensions, and unit weight differ. Please refer to P. 14 and P. 18 for details.

Main Specifications

		Item	Description
Lead		Lead (mm)	42 or equivalent
Horizontal	Payload	Max. payload (kg) [Controller power supply voltage 230VAC] (*1)	25
		Max. payload (kg) [Controller power supply voltage 115VAC] (*1)	17
	Speed / acceleration/ deceleration	Max. speed (mm/s)	3000
		Min. speed (mm/s)	2.57
		Rated acceleration/deceleration (G)	0.3
Vertical	Payload	Max. acceleration/deceleration (G)	2.0
		Max. payload (kg)	—
	Speed / acceleration/ deceleration	Max. speed (mm/s)	—
		Min. speed (mm/s)	—
		Rated acceleration/deceleration (G)	—
Thrust		Max. acceleration/deceleration (G)	—
Brake		Rated thrust (N)	71.2
		Brake specification	—
Stroke		Brake holding force (kgf)	—
		Min. stroke (mm)	200
		Max. stroke (mm)	3200
		Stroke pitch (mm)	50

(*1) When selecting the double slider specification (W), the max. payload is reduced. Please refer to the table below for more information.

Item	Description
Drive system	Timing belt, lead 42mm equivalent
Positioning repeatability	±0.04mm
Lost motion	0.1mm or less
Base	Material: Aluminum, white alumite treatment
Linear guide	Linear motion infinite circulating type
Static allowable moment (single slider specification)	Ma: 259N-m
	Mb: 369N-m
	Mc: 604N-m
Static allowable moment (double slider specification) (*2)	Ma: 1760N-m
	Mb: 2520N-m
	Mc: 1210N-m
Dynamic allowable moment (single slider specification) (*3)	Ma: 81.0N-m
	Mb: 116N-m
	Mc: 189N-m
Dynamic allowable moment (double slider specification) (*3)	Ma: Actual slider span min. [80mm] 448N-m, max. [120mm] 561N-m
	Mb: Actual slider span min. [80mm] 640N-m, max. [120mm] 801N-m
	Mc: Actual slider span min. [80mm] 307N-m, max. [120mm] 307N-m
Ambient operating temperature, humidity	0 ~ 40°C, 85% RH or less (Non-condensing)
Ingress protection	IP20
Vibration/shock resistance	4.9m/s ²
Compliant standards	CE marking, RoHS directive
Motor type	AC servo motor
Encoder type	Battery-less absolute
Number of encoder pulses	16384 pulse/rev

(*2) The figures are uniform regardless of slider span.

(*3) Based on the standard rated operation life of 10000km. Operation life varies according to operating and mounting conditions. Contact IAI to check the operation life.

Slider Type Moment Direction

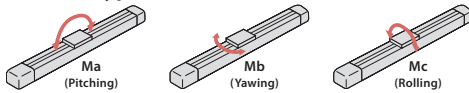

Table of Payload by Speed/Acceleration

The unit for payload is kg.

Lead (mm)	Max. speed (mm/s)	Orientation Controller power supply voltage	Horizontal Acceleration (G)																	
			0.3	0.4	0.5	0.6	0.7	0.8	0.9	1.0	1.1	1.2	1.3	1.4	1.5	1.6	1.7	1.8	1.9	2.0
42	3000	AC230V	25	18	14	11	9	7.5	6.5	5.5	4.6	3.8	3.2	2.6	2.3	2	1.7	1.4	1.2	1
		AC115V	17	11	8	6.5	5.5	4.5	4	3.5	3.2	2.9	2.7	2.6	2.3	2	1.7	1.4	1.2	1

Table of Payload by Speed/Acceleration (double slider specification)

The unit for payload is kg. If blank, operation is not possible.

Lead (mm)	Max. speed (mm/s)	Orientation Controller power supply voltage	Horizontal Acceleration (G)																	
			0.3	0.4	0.5	0.6	0.7	0.8	0.9	1.0	1.1	1.2	1.3	1.4	1.5	1.6	1.7	1.8	1.9	2.0
42	3000	AC230V	21	14	10	7	5	3.5	2.5	1.5	0.6									
		AC115V	13	7	4	2.5	1.5	0.5												

Stroke and Max. Speed

200 ~ 3200 (every 50mm)
3000

(Unit: mm/s)

Dimensions

CAD drawings can be downloaded from our website.
www.intelligentactuator.de



IFA-MA1 (upward facing motor)

(Note) Connect the motor cable and encoder cable to the cable joint connector. Please refer to P. 30 for cable details.
 (Note) When the slider is returning to its home position, be careful of interference from surrounding objects, as it will travel until it reaches the M.E.
 (Note) Be aware that the product must be returned to IA1 in order to change the home direction.
 (Note) The figure below shows MA1L.

ST: Stroke
M.E: Mechanical end
S.E: Stroke end

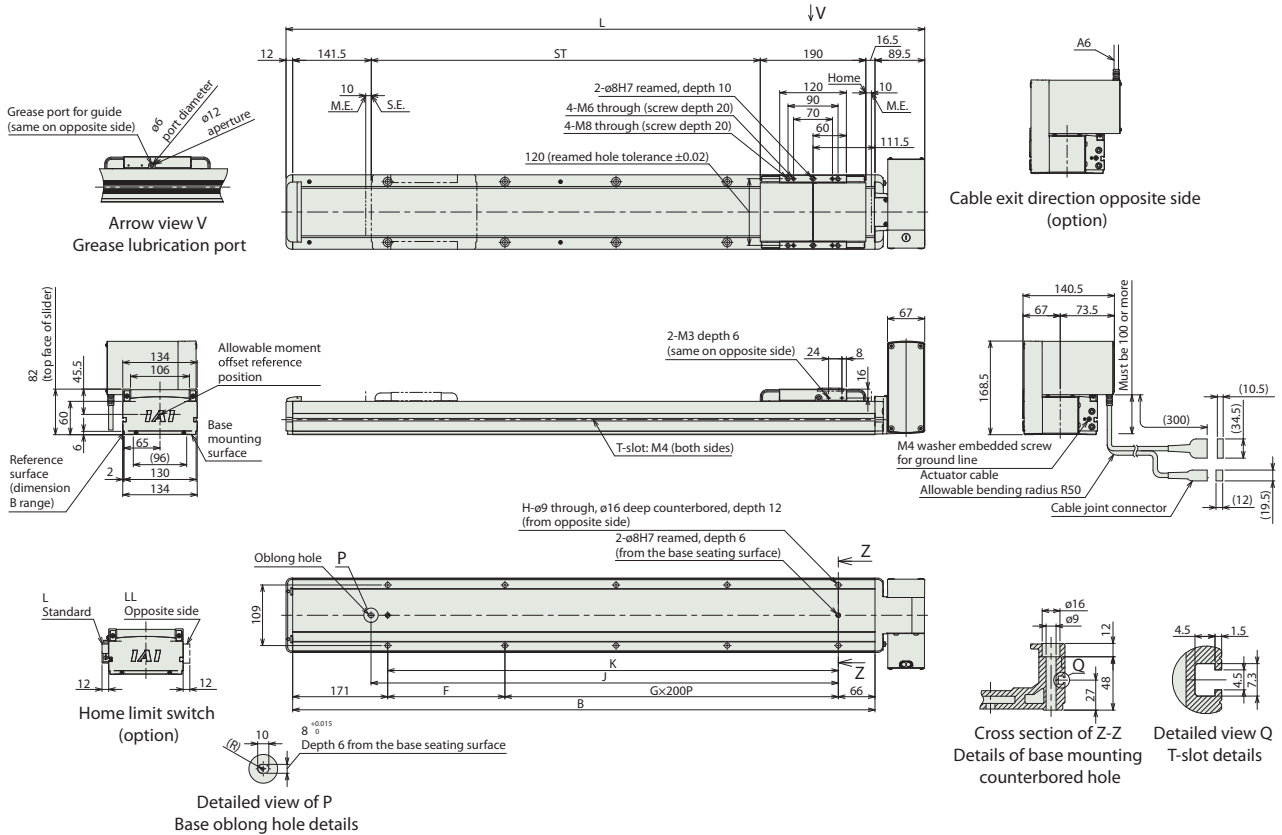

Dimensions by Stroke

Stroke	200	250	300	350	400	450	500	550	600	650	700	750	800	850	900	950	1000	1050	1100	1150	1200	1250	1300	1350	1400	1450	1500	1550	1600	1650	1700		
L	649.5	699.5	749.5	799.5	849.5	899.5	949.5	999.5	1049.5	1099.5	1149.5	1199.5	1249.5	1299.5	1349.5	1399.5	1449.5	1499.5	1549.5	1599.5	1649.5	1699.5	1749.5	1799.5	1849.5	1899.5	1949.5	1999.5	2049.5	2099.5	2149.5		
B	548	598	648	698	748	798	848	898	948	998	1048	1098	1148	1198	1248	1298	1348	1398	1448	1498	1548	1598	1648	1698	1748	1798	1848	1898	1948	1998	2048		
F	111	161	211	261	311	361	411	461	511	561	611	661	711	761	811	861	911	961	1011	1061	1111	1161	1211	1261	1311	1361	1411	1461	1511	1561	1611	1661	1711
G	1	1	1	2	2	2	2	3	3	3	3	4	4	4	4	5	5	5	5	6	6	6	6	7	7	7	7	8	8	8	8		
H	6	6	6	8	8	8	10	10	10	10	10	12	12	12	12	14	14	14	14	16	16	16	16	18	18	18	18	20	20	20	20		
J	341	391	441	491	541	591	641	691	741	791	841	891	941	991	1041	1091	1141	1191	1241	1291	1341	1391	1441	1491	1541	1591	1641	1691	1741	1791	1841		
K	311	361	411	461	511	561	611	661	711	761	811	861	911	961	1011	1061	1111	1161	1211	1261	1311	1361	1411	1461	1511	1561	1611	1661	1711	1761	1811		

Stroke	1750	1800	1850	1900	1950	2000	2050	2100	2150	2200	2250	2300	2350	2400	2450	2500	2550	2600	2650	2700	2750	2800	2850	2900	2950	3000	3050	3100	3150	3200	
L	2199.5	2249.5	2299.5	2349.5	2399.5	2449.5	2499.5	2549.5	2599.5	2649.5	2699.5	2749.5	2799.5	2849.5	2899.5	2949.5	2999.5	3049.5	3099.5	3149.5	3199.5	3249.5	3299.5	3349.5	3399.5	3449.5	3499.5	3549.5	3599.5	3649.5	
B	2098	2148	2198	2248	2298	2348	2398	2448	2498	2548	2598	2648	2698	2748	2798	2848	2898	2948	2998	3048	3098	3148	3198	3248	3298	3348	3398	3448	3498	3548	
F	61	111	161	211	261	311	361	411	461	511	561	611	661	711	761	811	861	911	961	1011	1061	1111	1161	1211	1261	1311	1361	1411	1461	1511	1561
G	9	9	9	9	10	10	10	10	11	11	11	11	11	12	12	12	13	13	13	13	14	14	14	14	15	15	15	15	16	16	
H	22	22	22	22	24	24	24	24	24	26	26	26	26	28	28	28	28	30	30	30	30	32	32	32	32	34	34	34	34	36	36
J	1891	1941	1991	2041	2091	2141	2191	2241	2291	2341	2391	2441	2491	2541	2591	2641	2691	2741	2791	2841	2891	2941	2991	3041	3091	3141	3191	3241	3291	3341	
K	1861	1911	1961	2011	2061	2111	2161	2211	2261	2311	2361	2411	2461	2511	2561	2611	2661	2711	2761	2811	2861	2911	2961	3011	3061	3111	3161	3211	3261	3311	

Mass by Stroke

Stroke	200	250	300	350	400	450	500	550	600	650	700	750	800	850	900	950	1000	1050	1100	1150	1200	1250	1300	1350	1400	1450	1500	1550	1600	1650	1700
Mass (kg)	10.8	11.3	11.8	12.3	12.8	13.3	13.8	14.3	14.9	15.4	15.9	16.4	16.9	17.4	17.9	18.4	19.0	19.5	20.0	20.5	21.0	21.5	22.0	22.5	23.0	23.6	24.1	24.6	25.1	25.6	26.1

Stroke	1750	1800	1850	1900	1950	2000	2050	2100	2150	2200	2250	2300	2350	2400	2450	2500	2550	2600	2650	2700	2750	2800	2850	2900	2950	3000	3050	3100	3150	3200
Mass (kg)	26.6	27.1	27.7	28.2	28.7	29.2	29.7	30.2	30.7	31.2	31.8	32.3	32.8	33.3	33.8	34.3	34.8	35.3	35.9	36.4	36.9	37.4	37.9	38.4	38.9	39.4	40.0	40.5	41.0	41.5

■ IFA-MA2 (horizontal motor)

(Note) Connect the motor cable and encoder cable to the cable joint connector. Please refer to P. 30 for cable details.
 (Note) When the slider is returning to its home position, be careful of interference from surrounding objects, as it will travel until it reaches the M.E.
 (Note) Be aware that the product must be returned to IA| in order to change the home direction.
 (Note) The figure below shows MA2L.

ST: Stroke
 M.E: Mechanical end
 S.E: Stroke end

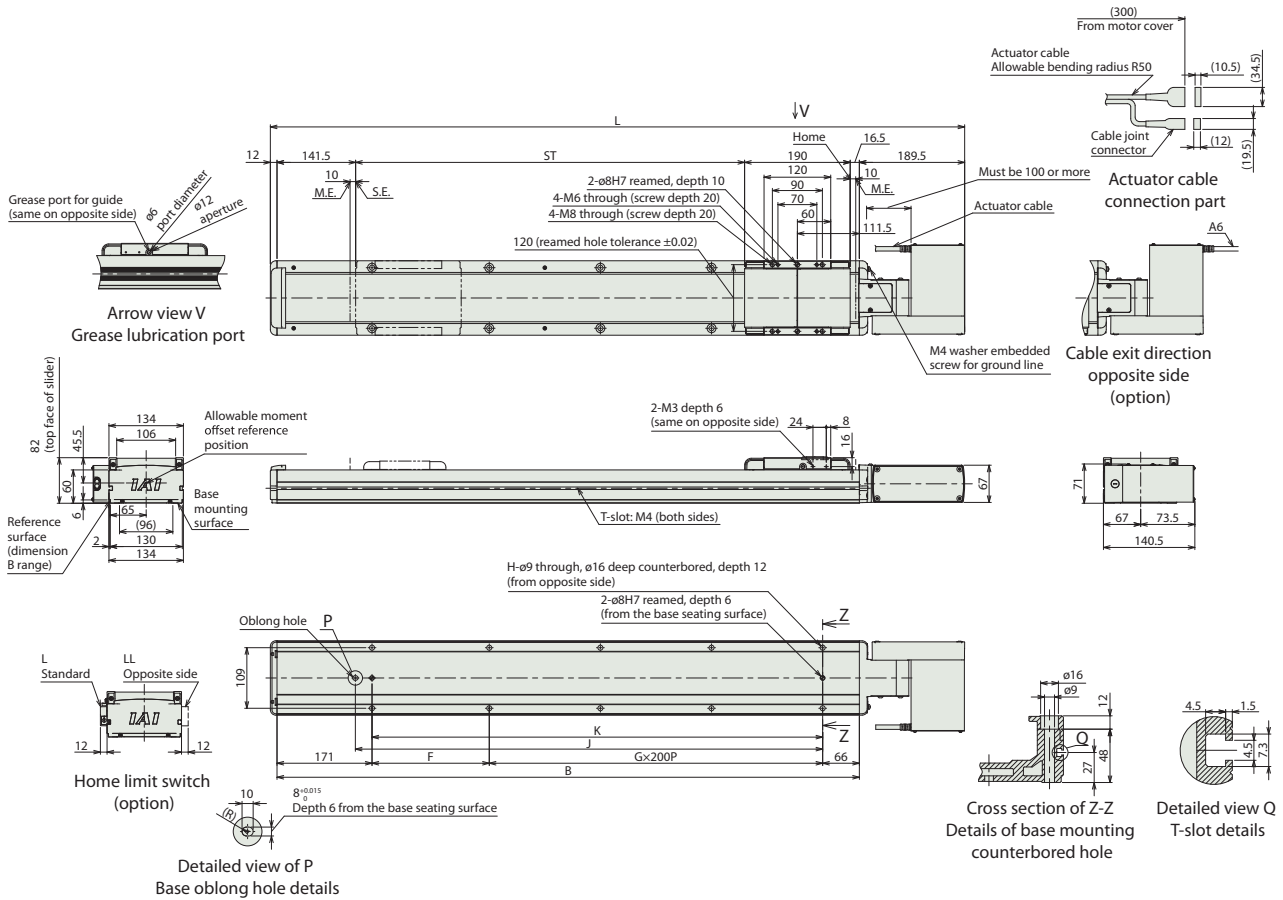

■ Dimensions by Stroke

Stroke	200	250	300	350	400	450	500	550	600	650	700	750	800	850	900	950	1000	1050	1100	1150	1200	1250	1300	1350	1400	1450	1500	1550	1600	1650	1700
L	749.5	799.5	849.5	899.5	949.5	999.5	1049.5	1099.5	1149.5	1199.5	1249.5	1299.5	1349.5	1399.5	1449.5	1499.5	1549.5	1599.5	1649.5	1699.5	1749.5	1799.5	1849.5	1899.5	1949.5	1999.5	2049.5	2099.5	2149.5	2199.5	2249.5
B	548	598	648	698	748	798	848	898	948	998	1048	1098	1148	1198	1248	1298	1348	1398	1448	1498	1548	1598	1648	1698	1748	1798	1848	1898	1948	1998	2048
F	111	161	211	261	311	361	411	461	511	561	611	661	711	761	811	861	911	961	1011	1061	1111	1161	1211	1261	1311	1361	1411	1461	1511	1561	1611
G	1	1	1	2	2	2	2	3	3	3	3	4	4	4	4	5	5	5	5	6	6	6	6	7	7	7	7	8	8	8	8
H	6	6	6	8	8	8	8	10	10	10	10	12	12	12	12	14	14	14	14	16	16	16	16	18	18	18	18	20	20	20	20
J	341	391	441	491	541	591	641	691	741	791	841	891	941	991	1041	1091	1141	1191	1241	1291	1341	1391	1441	1491	1541	1591	1641	1691	1741	1791	1841
K	311	361	411	461	511	561	611	661	711	761	811	861	911	961	1011	1061	1111	1161	1211	1261	1311	1361	1411	1461	1511	1561	1611	1661	1711	1761	1811

Stroke	1750	1800	1850	1900	1950	2000	2050	2100	2150	2200	2250	2300	2350	2400	2450	2500	2550	2600	2650	2700	2750	2800	2850	2900	2950	3000	3050	3100	3150	3200	
L	2299.5	2349.5	2399.5	2449.5	2499.5	2549.5	2599.5	2649.5	2699.5	2749.5	2799.5	2849.5	2899.5	2949.5	2999.5	3049.5	3099.5	3149.5	3199.5	3249.5	3299.5	3349.5	3399.5	3449.5	3499.5	3549.5	3599.5	3649.5	3699.5	3749.5	
B	2098	2148	2198	2248	2298	2348	2398	2448	2498	2548	2598	2648	2698	2748	2798	2848	2898	2948	2998	3048	3098	3148	3198	3248	3298	3348	3398	3448	3498	3548	
F	61	111	161	211	261	311	361	411	461	511	561	611	661	711	761	811	861	911	961	1011	1061	1111	1161	1211	1261	1311	1361	1411	1461	1511	
G	9	9	9	9	10	10	10	10	11	11	11	11	12	12	12	12	13	13	13	13	14	14	14	14	15	15	15	15	16	16	16
H	22	22	22	22	24	24	24	24	26	26	26	26	28	28	28	28	30	30	30	30	32	32	32	32	34	34	34	34	36	36	36
J	1891	1941	1991	2041	2091	2141	2191	2241	2291	2341	2391	2441	2491	2541	2591	2641	2691	2741	2791	2841	2891	2941	2991	3041	3091	3141	3191	3241	3291	3341	
K	1861	1911	1961	2011	2061	2111	2161	2211	2261	2311	2361	2411	2461	2511	2561	2611	2661	2711	2761	2811	2861	2911	2961	3011	3061	3111	3161	3211	3261	3311	

■ Mass by Stroke

Stroke	200	250	300	350	400	450	500	550	600	650	700	750	800	850	900	950	1000	1050	1100	1150	1200	1250	1300	1350	1400	1450	1500	1550	1600	1650	1700
Mass (kg)	10.8	11.3	11.8	12.3	12.8	13.3	13.8	14.3	14.9	15.4	15.9	16.4	16.9	17.4	17.9	18.4	19.0	19.5	20.0	20.5	21.0	21.5	22.0	22.5	23.0	23.6	24.1	24.6	25.1	25.6	26.1

Stroke	1750	1800	1850	1900	1950	2000	2050	2100	2150	2200	2250	2300	2350	2400	2450	2500	2550	2600	2650	2700	2750	2800	2850	2900	2950	3000	3050	3100	3150	3200
Mass (kg)	26.6	27.1	27.7	28.2	28.7	29.2	29.7	30.2	30.7	31.2	31.8	32.3	32.8	33.3	33.8	34.3	34.8	35.3	35.9	36.4	36.9	37.4	37.9	38.4	38.9	39.4	40.0	40.5	41.0	41.5

IFA-MA3 (downward facing motor)

(Note) Connect the motor cable and encoder cable to the cable joint connector. Please refer to P. 30 for cable details.
 (Note) When the slider is returning to its home position, be careful of interference from surrounding objects, as it will travel until it reaches the M.E.
 (Note) Be aware that the product must be returned to IAI in order to change the home direction.
 (Note) The figure below shows MA3L.

ST: Stroke
 M.E.: Mechanical end
 S.E.: Stroke end

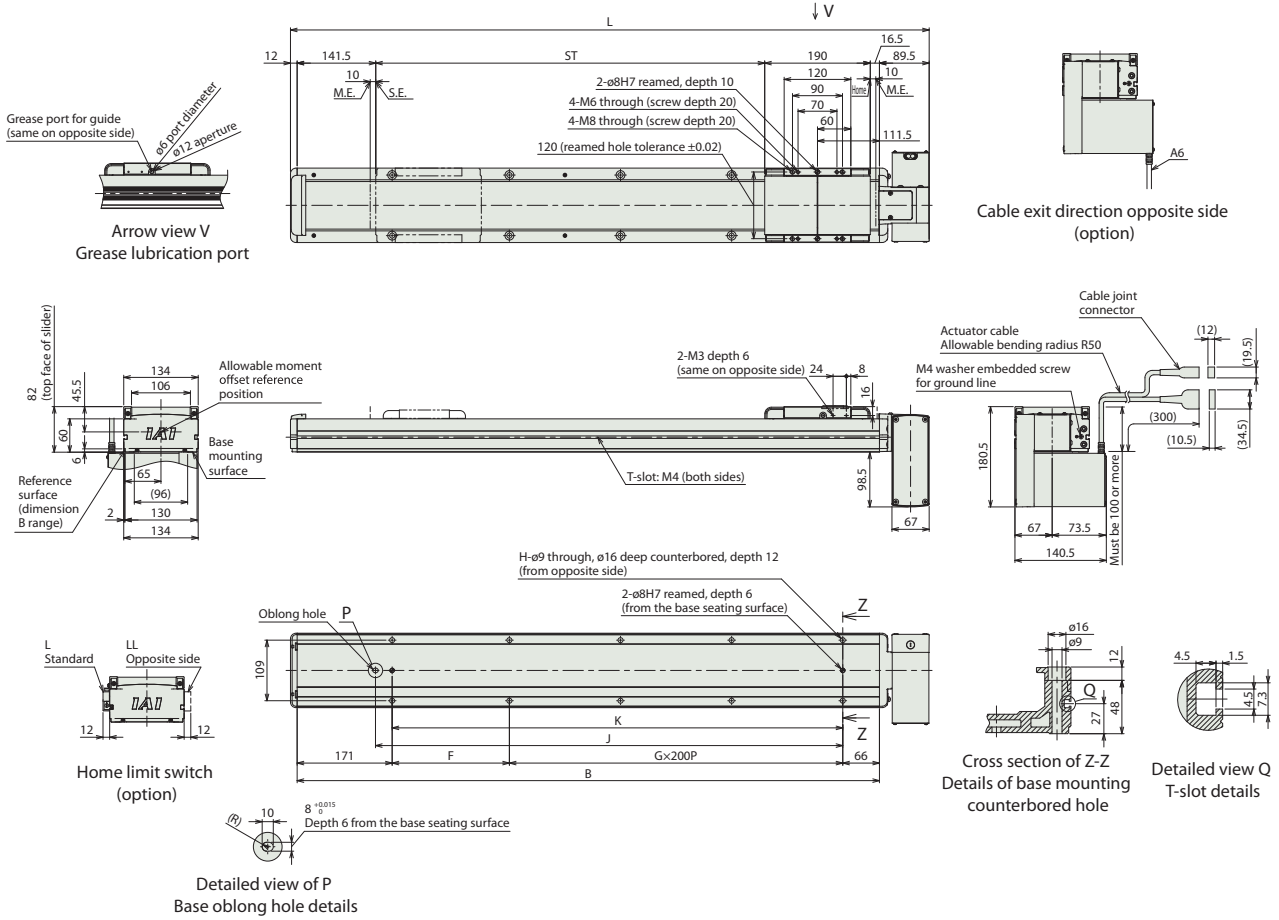

Dimensions by Stroke

Stroke	200	250	300	350	400	450	500	550	600	650	700	750	800	850	900	950	1000	1050	1100	1150	1200	1250	1300	1350	1400	1450	1500	1550	1600	1650	1700
L	649.5	699.5	749.5	799.5	849.5	899.5	949.5	999.5	1049.5	1099.5	1149.5	1199.5	1249.5	1299.5	1349.5	1399.5	1449.5	1499.5	1549.5	1599.5	1649.5	1699.5	1749.5	1799.5	1849.5	1899.5	1949.5	1999.5	2049.5	2099.5	2149.5
B	548	598	648	698	748	798	848	898	948	998	1048	1098	1148	1198	1248	1298	1348	1398	1448	1498	1548	1598	1648	1698	1748	1798	1848	1898	1948	1998	2048
F	111	161	211	261	311	361	411	461	511	561	611	661	711	761	811	861	911	961	1011	1061	1111	1161	1211	1261	1311	1361	1411	1461	1511	1561	1611
G	1	1	1	2	2	2	2	3	3	3	3	3	4	4	4	4	5	5	5	5	6	6	6	6	7	7	7	8	8	8	8
H	6	6	6	8	8	8	8	10	10	10	10	12	12	12	12	14	14	14	14	16	16	16	16	18	18	18	18	20	20	20	20
J	341	391	441	491	541	591	641	691	741	791	841	891	941	991	1041	1091	1141	1191	1241	1291	1341	1391	1441	1491	1541	1591	1641	1691	1741	1791	1841
K	311	361	411	461	511	561	611	661	711	761	811	861	911	961	1011	1061	1111	1161	1211	1261	1311	1361	1411	1461	1511	1561	1611	1661	1711	1761	1811

Stroke	1750	1800	1850	1900	1950	2000	2050	2100	2150	2200	2250	2300	2350	2400	2450	2500	2550	2600	2650	2700	2750	2800	2850	2900	2950	3000	3050	3100	3150	3200	
L	2199.5	2249.5	2299.5	2349.5	2399.5	2449.5	2499.5	2549.5	2599.5	2649.5	2699.5	2749.5	2799.5	2849.5	2899.5	2949.5	2999.5	3049.5	3099.5	3149.5	3199.5	3249.5	3299.5	3349.5	3399.5	3449.5	3499.5	3549.5	3599.5	3649.5	
B	2098	2148	2198	2248	2298	2348	2398	2448	2498	2548	2598	2648	2698	2748	2798	2848	2898	2948	2998	3048	3098	3148	3198	3248	3298	3348	3398	3448	3498	3548	
F	61	111	161	211	261	311	361	411	461	511	561	611	661	711	761	811	861	911	961	1011	1061	1111	1161	1211	1261	1311	1361	1411	1461	1511	
G	9	9	9	9	10	10	10	10	10	11	11	11	11	12	12	12	12	13	13	13	13	14	14	14	14	15	15	15	15	16	16
H	22	22	22	22	24	24	24	24	26	26	26	26	28	28	28	28	30	30	30	30	32	32	32	32	34	34	34	34	36	36	
J	1891	1941	1991	2041	2091	2141	2191	2241	2291	2341	2391	2441	2491	2541	2591	2641	2691	2741	2791	2841	2891	2941	2991	3041	3091	3141	3191	3241	3291	3341	
K	1861	1911	1961	2011	2061	2111	2161	2211	2261	2311	2361	2411	2461	2511	2561	2611	2661	2711	2761	2811	2861	2911	2961	3011	3061	3111	3161	3211	3261	3311	

Mass by Stroke

Stroke	200	250	300	350	400	450	500	550	600	650	700	750	800	850	900	950	1000	1050	1100	1150	1200	1250	1300	1350	1400	1450	1500	1550	1600	1650	1700
Mass (kg)	10.8	11.3	11.8	12.3	12.8	13.3	13.8	14.3	14.9	15.4	15.9	16.4	16.9	17.4	17.9	18.4	19.0	19.5	20.0	20.5	21.0	21.5	22.0	22.5	23.0	23.6	24.1	24.6	25.1	25.6	26.1

Stroke	1750	1800	1850	1900	1950	2000	2050	2100	2150	2200	2250	2300	2350	2400	2450	2500	2550	2600	2650	2700	2750	2800	2850	2900	2950	3000	3050	3100	3150	3200
Mass (kg)	26.6	27.1	27.7	28.2	28.7	29.2	29.7	30.2	30.7	31.2	31.8	32.3	32.8	33.3	33.8	34.3	34.8	35.3	35.9	36.4	36.9	37.4	37.9	38.4	38.9	39.4	40.0	40.5	41.0	41.5

Dimension for double slider specification

(Note) Connect the motor cable and encoder cable to the cable joint connector. Please refer to P. 30 for cable details.
 (Note) When the slider is returning to its home position, be careful of interference from surrounding objects, as it will travel until it reaches the M.E.
 (Note) Be aware that the product must be returned to IA1 in order to change the home direction.
 (Note) The figure below shows MA1L.
 (Note) The figure below shows dimensions at minimum actual slider span.

CAD drawings can be downloaded from our website.
www.intelligentactor.de

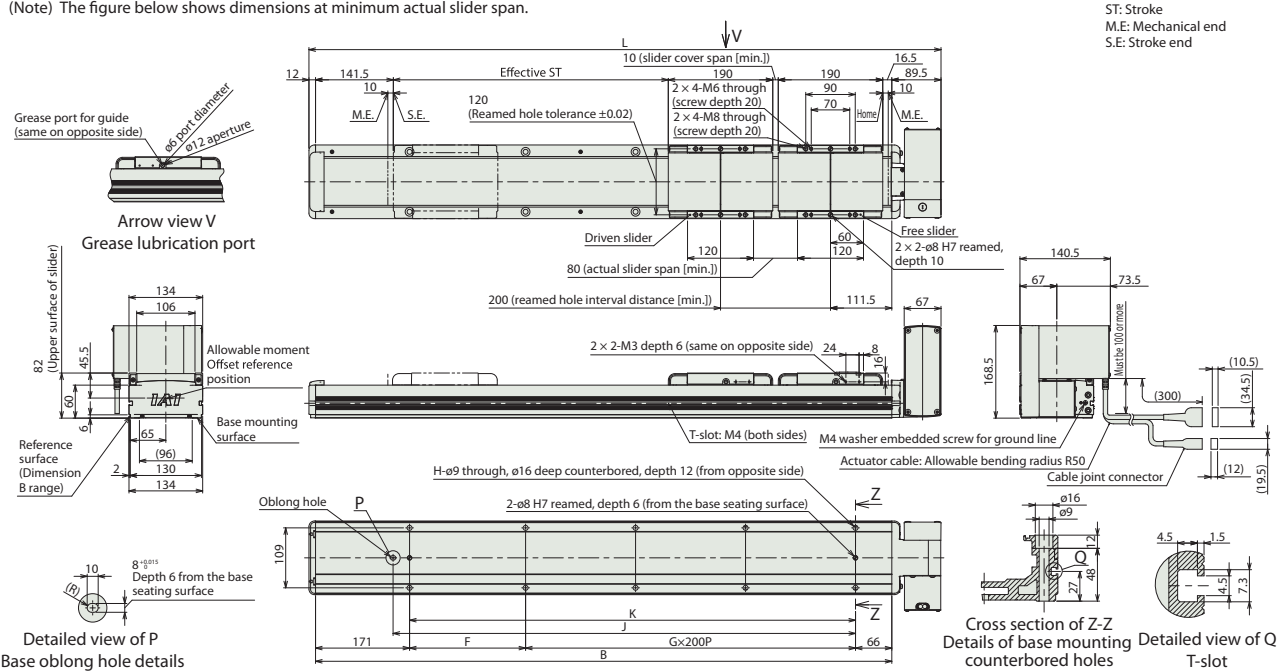

Dimensions by Stroke

Nominal stroke	400	450	500	550	600	650	700	750	800	850	900	950	1000	1050	1100	1150	1200	1250	1300	1350	1400	1450	1500	1550	1600	1650	1700	1750	1800
Effective stroke	200	250	300	350	400	450	500	550	600	650	700	750	800	850	900	950	1000	1050	1100	1150	1200	1250	1300	1350	1400	1450	1500	1550	1600
L	849.5	899.5	949.5	999.5	1049.5	1099.5	1149.5	1199.5	1249.5	1299.5	1349.5	1399.5	1449.5	1499.5	1549.5	1599.5	1649.5	1699.5	1749.5	1799.5	1849.5	1899.5	1949.5	1999.5	2049.5	2099.5	2149.5	2199.5	2249.5
B	748	798	848	898	948	998	1048	1098	1148	1198	1248	1298	1348	1398	1448	1498	1548	1598	1648	1698	1748	1798	1848	1898	1948	1998	2048	2098	2148
F	111	161	211	261	311	361	411	461	511	561	611	661	711	761	811	861	911	961	1011	1061	1111	1161	1211	1261	1311	1361	1411	1461	1511
G	2	2	2	3	3	3	3	3	4	4	4	4	5	5	5	5	6	6	6	6	7	7	7	8	8	8	8	9	9
H	8	8	8	10	10	10	10	10	12	12	12	12	14	14	14	14	16	16	16	16	18	18	18	18	20	20	20	22	22
J	541	591	641	691	741	791	841	891	941	991	1041	1091	1141	1191	1241	1291	1341	1391	1441	1491	1541	1591	1641	1691	1741	1791	1841	1891	1941
K	511	561	611	661	711	761	811	861	911	961	1011	1061	1111	1161	1211	1261	1311	1361	1411	1461	1511	1561	1611	1661	1711	1761	1811	1861	1911

Nominal stroke	1850	1900	1950	2000	2050	2100	2150	2200	2250	2300	2350	2400	2450	2500	2550	2600	2650	2700	2750	2800	2850	2900	2950	3000	3050	3100	3150	3200
Effective stroke	1650	1700	1750	1800	1850	1900	1950	2000	2050	2100	2150	2200	2250	2300	2350	2400	2450	2500	2550	2600	2650	2700	2750	2800	2850	2900	2950	3000
L	2299.5	2349.5	2399.5	2449.5	2499.5	2549.5	2599.5	2649.5	2699.5	2749.5	2799.5	2849.5	2899.5	2949.5	2999.5	3049.5	3099.5	3149.5	3199.5	3249.5	3299.5	3349.5	3399.5	3449.5	3499.5	3549.5	3599.5	3649.5
B	2198	2248	2298	2348	2398	2448	2498	2548	2598	2648	2698	2748	2798	2848	2898	2948	2998	3048	3098	3148	3198	3248	3298	3348	3398	3448	3498	3548
F	161	211	261	311	361	411	461	511	561	611	661	711	761	811	861	911	961	1011	1061	1111	1161	1211	1261	1311	1361	1411	1461	1511
G	9	9	10	10	10	10	11	11	11	11	12	12	12	13	13	13	13	14	14	14	15	15	15	16	16	16	16	16
H	22	22	24	24	24	24	26	26	26	26	28	28	28	30	30	30	30	32	32	32	32	34	34	34	34	36	36	36
J	1991	2041	2091	2141	2191	2241	2291	2341	2391	2441	2491	2541	2591	2641	2691	2741	2791	2841	2891	2941	2991	3041	3091	3141	3191	3241	3291	3341
K	1961	2011	2061	2111	2161	2211	2261	2311	2361	2411	2461	2511	2561	2611	2661	2711	2761	2811	2861	2911	2961	3011	3061	3111	3161	3211	3261	3311

(Note) Nominal stroke: Stroke listed in the model name; effective stroke: actually operable stroke

Mass by Stroke

Nominal stroke	400	450	500	550	600	650	700	750	800	850	900	950	1000	1050	1100	1150	1200	1250	1300	1350	1400	1450	1500	1550	1600	1650	1700	1750	1800
Effective stroke	200	250	300	350	400	450	500	550	600	650	700	750	800	850	900	950	1000	1050	1100	1150	1200	1250	1300	1350	1400	1450	1500	1550	1600
Mass (kg)	14.3	14.8	15.3	15.8	16.4	16.9	17.4	17.9	18.4	18.9	19.4	19.9	20.5	21.0	21.5	22.0	22.5	23.0	23.5	24.0	24.5	25.1	25.6	26.1	26.6	27.1	27.6	28.1	28.6

Nominal stroke	1850	1900	1950	2000	2050	2100	2150	2200	2250	2300	2350	2400	2450	2500	2550	2600	2650	2700	2750	2800	2850	2900	2950	3000	3050	3100	3150	3200
Effective stroke	1650	1700	1750	1800	1850	1900	1950	2000	2050	2100	2150	2200	2250	2300	2350	2400	2450	2500	2550	2600	2650	2700	2750	2800	2850	2900	2950	3000
Mass (kg)	29.2	29.7	30.2	30.7	31.2	31.7	32.2	32.7	33.3	33.8	34.3	34.8	35.3	35.8	36.3	36.8	37.4	37.9	38.4	38.9	39.4	39.9	40.4	40.9	41.5	42.0	42.5	43.0

(Note) The above mass values are for double slider specification. It is the sum of single slider specification's mass and free slider's mass (1.5kg)

Applicable Controllers

The actuator on this page can be operated with the controllers below. Select a type suited to the application.

Name	External view	Max. number of connectable axes	Power supply voltage	Control method														Max. number of positioning points	Reference page	
				Positioner	Pulse-train	Program	Network option *													
				DV	CC	CIE	PR	CN	ML	ML3	EC	EP	PRT	SSN	ECM					
RCON		16	DC24V Single phase 230VAC Three-phase 230VAC	—	—	—	●	●	●	●	—	—	—	●	●	●	—	●	128	Please see the dedicated catalog or manual.
RSEL		8	—	—	—	●	●	●	●	—	—	—	—	●	●	●	—	—	36000	
SCON-CB/CGB		1	Single phase AC 115V/230V	●	●	—	●	●	●	—	—	—	—	●	●	●	—	●	512 (768 for network specification)	
SSEL-CS		2	—	●	—	—	●	●	●	—	—	—	—	—	—	—	—	—	20000	
XSEL-P/Q		6	Single phase 230VAC	—	—	●	●	●	●	—	—	—	—	—	—	—	—	—	20000	
XSEL-RA/SA		8	Three-phase 230VAC	—	—	●	●	●	●	—	—	—	—	—	—	—	—	—	55000 (varies by type)	

* Network abbreviations: DV - DeviceNet | CC - CC-Link | CIE - CC-Link IE | PR - Profibus-DP | CN - CompoNet | ML - Mechatrolink | ML3 - Mechatrolink-III | EC - EtherCAT | EP - Ethernet/IP | PRT - Profinet-IO | SSN - SSCNET III/H | ECM - EtherCAT Motion

IFA-MA□□-400

Simple Dust-proof	Battery-less Absolute	Body Width 130 mm	400 W	Belt Type
-------------------	-----------------------	-------------------	-------	-----------

Model Specification Items

IFA	WA	400	Stroke	Applicable controllers	Cable length	Option
Series	Encoder type	Motor type	200 200mm 3200 3200mm (every 50mm)	T2 SCON SSEL XSEL-P/Q XSEL-RA/SA T4 RCON RSEL	N No S 3m M 5m X□□ Specified length	Please refer to the options table below.
Type	WA Battery-less absolute	400 400W				
MA1L Upward facing motor						
MA2L Horizontal motor						
MA3L Downward facing motor						
MA1R Upward facing motor opposite side						
MA2R Horizontal motor opposite side						
MA3R Downward facing motor opposite side						

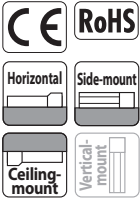

(Note) Photo above shows upward facing motor specification (MA1L).

POINT Selection Notes

- (1) Pay close attention to the mounting orientation. Please refer to P. 5 for details.
- (2) "Main Specifications" displays the payload's maximum value. Please refer to "Table of Payload by Speed/Acceleration" for more details.
- (3) Push-motion operation cannot be performed.
- (4) Estimated allowable duty ratio varies depending on load factor. Refer to P. 27 for details.
- (5) The center mass location of the attached object should be less than 1/2 of the overhang distance. Operating conditions should be moderated if abnormal vibration or noise is observed, even if the overhang distance and load moment are within allowable values.
- (6) Reference value of the overhang load length is under 600mm in the Ma, Mb, and Mc directions (for double slider specification, the actual slider span is min. [80mm]: 1600mm, max. [120mm]: 1800mm or below). Please refer to the explanation on P. 5 for the overhang load length.
- (7) When selecting the double slide specification, please refer to P. 26 for models to be ordered and precautions.

Cable Length

Type	Cable Code
Standard	S (3m)
	M (5m)
Specified length	X06(6m) ~ X10 (10m)
	X11 (11m) ~ X15 (15m)
	X16 (16m) ~ X20 (20m)
	X21 (21m) ~ X25 (25m)
	X26(26m) ~ X30 (30m)

(Note) This is a robot cable.

Options * Please check the options reference pages to confirm each option.

Name	Model	Reference page
Cable exit direction opposite side	A6	25
AQ seal (equipped as standard) (Note 1)	AQ	25
Ceiling/side mounting specifications (Note 2)	CSM	25
Hanging brackets (Note 3)	EB	25
Home limit switch (Note 3)	L	25
Home limit switch opposite side (Note 3)	LL	25
Non-motor end specification	NM	25
Double slider specification (Note 4)	W	25
Round cable joint connector with screw locking	EU	25

- (Note 1) Be sure to fill in the option field in the model specification items.
 (Note 2) Also usable in horizontal mounting.
 (Note 3) Due to mutual interference, the hanging brackets (EB) and home limit switch (L/LL) cannot be used together.
 (Note 4) When selecting the double slider specification (W), the payload, dimensions, and unit weight differ. Please refer to P. 20 and P. 24 for details.

Main Specifications

Item		Description
Lead	Lead (mm)	42 or equivalent
Horizontal	Payload	Max. payload (kg) (*1)
	Speed / acceleration/ deceleration	Max. speed (mm/s)
		Min. speed (mm/s)
		Rated acceleration/deceleration (G)
		Max. acceleration/deceleration (G)
Vertical	Payload	—
	Speed / acceleration/ deceleration	Max. speed (mm/s)
		Min. speed (mm/s)
		Rated acceleration/deceleration (G)
		Max. acceleration/deceleration (G)
Thrust	Rated thrust (N)	142.4
Brake	Brake specification	—
	Brake holding force (kgf)	—
Stroke	Min. stroke (mm)	200
	Max. stroke (mm)	3200
	Stroke pitch (mm)	50

(*1) When selecting the double slider specification (W), the max. payload is reduced. Please refer to the table below for more information.

Item	Description
Drive system	Timing belt, lead 42mm equivalent
Positioning repeatability	±0.04mm
Lost motion	0.1mm or less
Base	Material: Aluminum, white alumite treatment
Linear guide	Linear motion infinite circulating type
Static allowable moment (single slider specification)	Ma: 259N-m
	Mb: 369N-m
	Mc: 604N-m
Static allowable moment (double slider specification) (*2)	Ma: 1760N-m
	Mb: 2520N-m
	Mc: 1210N-m
Dynamic allowable moment (single slider specification) (*3)	Ma: 81.0N-m
	Mb: 116N-m
	Mc: 189N-m
Dynamic allowable moment (double slider specification) (*3)	Ma: Actual slider span min. [80mm] 448N-m, max. [120mm] 561N-m
	Mb: Actual slider span min. [80mm] 640N-m, max. [120mm] 801N-m
	Mc: Actual slider span min. [80mm] 307N-m, max. [120mm] 307N-m
Ambient operating temperature, humidity	0 ~ 40°C, 85% RH or less (Non-condensing)
Ingress protection	IP20
Vibration/shock resistance	4.9m/s ²
Compliant standards	CE marking, RoHS directive
Motor type	AC servo motor
Encoder type	Battery-less absolute
Number of encoder pulses	16384 pulse/rev

(*2) The figures are uniform regardless of slider span.

(*3) Based on the standard rated operation life of 10000km. Operation life varies according to operating and mounting conditions. Contact IAI to check the operation life.

Slider Type Moment Direction

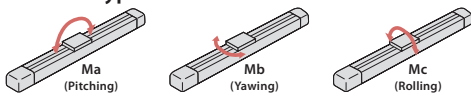

Table of Payload by Speed/Acceleration

The unit for payload is kg.

Orientation		Horizontal Acceleration (G)																	
Lead (mm)	Max. speed (mm/s)	0.3	0.4	0.5	0.6	0.7	0.8	0.9	1.0	1.1	1.2	1.3	1.4	1.5	1.6	1.7	1.8	1.9	2.0
42	3000	40	30	23	19	16	13	12	10	9	8	7	6.3	5.6	5	4.6	4.2	3.8	3.5

(Note) The specs are the same even with different controller power supply voltages.

Table of Payload by Speed/Acceleration (double slider specification)

The unit for payload is kg. If blank, operation is not possible.

Orientation		Horizontal Acceleration (G)																	
Lead (mm)	Max. speed (mm/s)	0.3	0.4	0.5	0.6	0.7	0.8	0.9	1.0	1.1	1.2	1.3	1.4	1.5	1.6	1.7	1.8	1.9	2.0
42	3000	36.5	26.5	19.5	15.5	12.5	9.5	8.5	6.5	5.5	4.5	3.5	2.8	2.1	1.5	1.1	0.7	0.3	

(Note) The specs are the same even with different controller power supply voltages.

Stroke and Max. Speed

200 ~ 3200 (every 50mm)
3000

(Unit: mm/s)

Dimensions

CAD drawings can be downloaded from our website.
www.intelligentactor.de



IFA-MA1 (upward facing motor)

(Note) Connect the motor cable and encoder cable to the cable joint connector. Please refer to P. 30 for cable details.
 (Note) When the slider is returning to its home position, be careful of interference from surrounding objects, as it will travel until it reaches the M.E.
 (Note) Be aware that the product must be returned to IA1 in order to change the home direction.
 (Note) The figure below shows MA1L.

ST: Stroke
M.E: Mechanical end
S.E: Stroke end

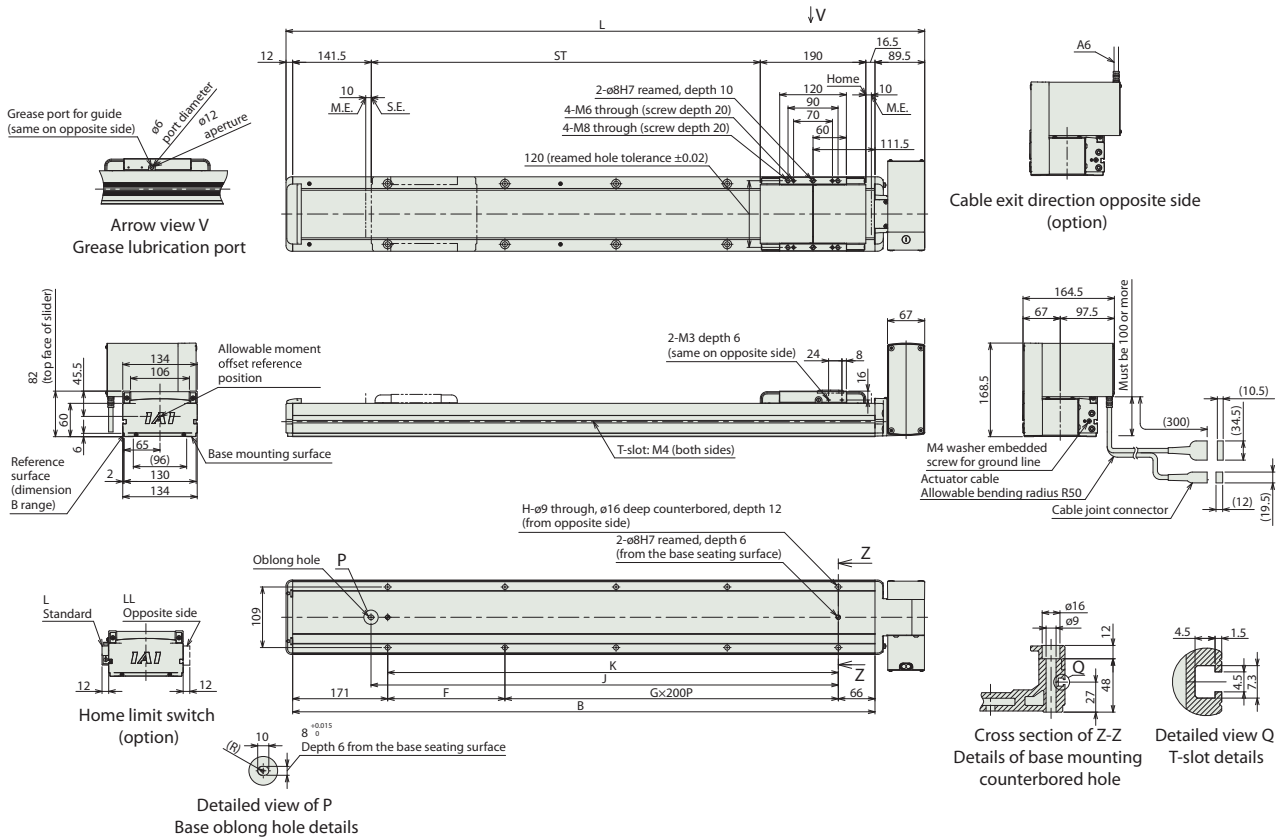

Dimensions by Stroke

Stroke	200	250	300	350	400	450	500	550	600	650	700	750	800	850	900	950	1000	1050	1100	1150	1200	1250	1300	1350	1400	1450	1500	1550	1600	1650	1700
L	649.5	699.5	749.5	799.5	849.5	899.5	949.5	999.5	1049.5	1099.5	1149.5	1199.5	1249.5	1299.5	1349.5	1399.5	1449.5	1499.5	1549.5	1599.5	1649.5	1699.5	1749.5	1799.5	1849.5	1899.5	1949.5	1999.5	2049.5	2099.5	2149.5
B	548	598	648	698	748	798	848	898	948	998	1048	1098	1148	1198	1248	1298	1348	1398	1448	1498	1548	1598	1648	1698	1748	1798	1848	1898	1948	1998	2048
F	111	161	211	261	311	361	411	461	511	561	611	661	711	761	811	861	911	961	1011	1061	1111	1161	1211	1261	1311	1361	1411	1461	1511	1561	1611
G	1	1	1	2	2	2	3	3	3	3	4	4	4	4	4	5	5	5	5	6	6	6	6	6	7	7	7	7	8	8	8
H	6	6	6	8	8	8	8	10	10	10	10	10	12	12	12	12	14	14	14	14	16	16	16	16	18	18	18	18	20	20	20
J	341	391	441	491	541	591	641	691	741	791	841	891	941	991	1041	1091	1141	1191	1241	1291	1341	1391	1441	1491	1541	1591	1641	1691	1741	1791	1841
K	311	361	411	461	511	561	611	661	711	761	811	861	911	961	1011	1061	1111	1161	1211	1261	1311	1361	1411	1461	1511	1561	1611	1661	1711	1761	1811

Stroke	1750	1800	1850	1900	1950	2000	2050	2100	2150	2200	2250	2300	2350	2400	2450	2500	2550	2600	2650	2700	2750	2800	2850	2900	2950	3000	3050	3100	3150	3200	
L	2199.5	2249.5	2299.5	2349.5	2399.5	2449.5	2499.5	2549.5	2599.5	2649.5	2699.5	2749.5	2799.5	2849.5	2899.5	2949.5	2999.5	3049.5	3099.5	3149.5	3199.5	3249.5	3299.5	3349.5	3399.5	3449.5	3499.5	3549.5	3599.5	3649.5	
B	2098	2148	2198	2248	2298	2348	2398	2448	2498	2548	2598	2648	2698	2748	2798	2848	2898	2948	2998	3048	3098	3148	3198	3248	3298	3348	3398	3448	3498	3548	
F	61	111	161	211	261	311	361	411	461	511	561	611	661	711	761	811	861	911	961	1011	1061	1111	1161	1211	1261	1311	1361	1411	1461	1511	
G	9	9	9	9	10	10	10	10	11	11	11	11	12	12	12	12	13	13	13	13	14	14	14	14	15	15	15	15	16	16	16
H	22	22	22	22	24	24	24	24	26	26	26	26	28	28	28	28	30	30	30	30	32	32	32	32	34	34	34	34	36	36	36
J	1891	1941	1991	2041	2091	2141	2191	2241	2291	2341	2391	2441	2491	2541	2591	2641	2691	2741	2791	2841	2891	2941	2991	3041	3091	3141	3191	3241	3291	3341	
K	1861	1911	1961	2011	2061	2111	2161	2211	2261	2311	2361	2411	2461	2511	2561	2611	2661	2711	2761	2811	2861	2911	2961	3011	3061	3111	3161	3211	3261	3311	

Mass by Stroke

Stroke	200	250	300	350	400	450	500	550	600	650	700	750	800	850	900	950	1000	1050	1100	1150	1200	1250	1300	1350	1400	1450	1500	1550	1600	1650	1700
Mass (kg)	11.2	11.7	12.2	12.7	13.2	13.8	14.3	14.8	15.3	15.8	16.3	16.8	17.3	17.9	18.4	18.9	19.4	19.9	20.4	20.9	21.4	22.0	22.5	23.0	23.5	24.0	24.5	25.0	25.5	26.1	26.6

Stroke	1750	1800	1850	1900	1950	2000	2050	2100	2150	2200	2250	2300	2350	2400	2450	2500	2550	2600	2650	2700	2750	2800	2850	2900	2950	3000	3050	3100	3150	3200
Mass (kg)	27.1	27.6	28.1	28.6	29.1	29.6	30.2	30.7	31.2	31.7	32.2	32.7	33.2	33.7	34.2	34.8	35.3	35.8	36.3	36.8	37.3	37.8	38.3	38.9	39.4	39.9	40.4	40.9	41.4	41.9

■ IFA-MA2 (horizontal motor)

(Note) Connect the motor cable and encoder cable to the cable joint connector. Please refer to P. 30 for cable details.
 (Note) When the slider is returning to its home position, be careful of interference from surrounding objects, as it will travel until it reaches the M.E.
 (Note) Be aware that the product must be returned to IAI in order to change the home direction.
 (Note) The figure below shows MA2L.

ST: Stroke
 M.E: Mechanical end
 S.E: Stroke end

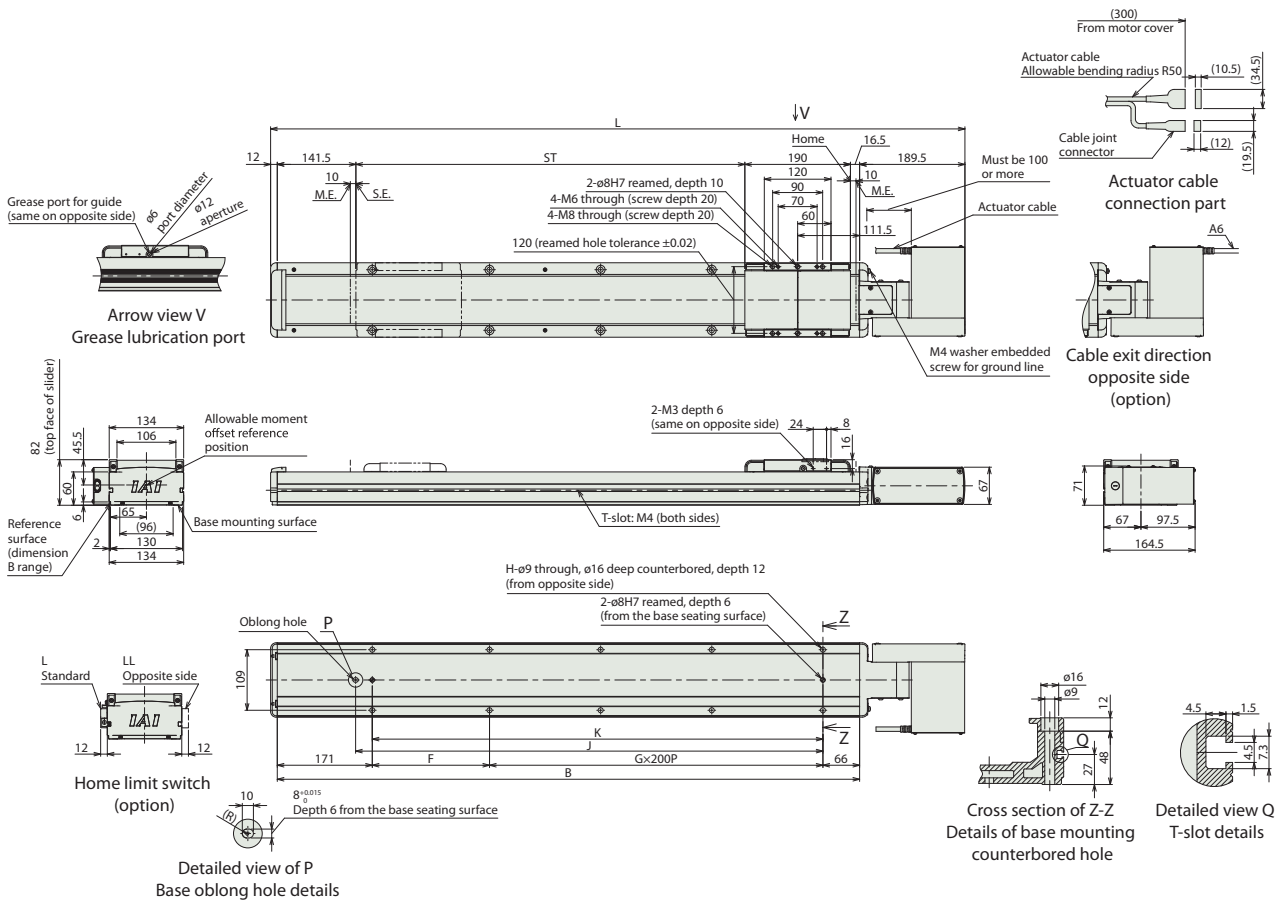

■ Dimensions by Stroke

Stroke	200	250	300	350	400	450	500	550	600	650	700	750	800	850	900	950	1000	1050	1100	1150	1200	1250	1300	1350	1400	1450	1500	1550	1600	1650	1700				
L	749.5	799.5	849.5	899.5	949.5	999.5	1049.5	1099.5	1149.5	1199.5	1249.5	1299.5	1349.5	1399.5	1449.5	1499.5	1549.5	1599.5	1649.5	1699.5	1749.5	1799.5	1849.5	1899.5	1949.5	1999.5	2049.5	2099.5	2149.5	2199.5	2249.5				
B	548	598	648	698	748	798	848	898	948	998	1048	1098	1148	1198	1248	1298	1348	1398	1448	1498	1548	1598	1648	1698	1748	1798	1848	1898	1948	1998	2048				
F	111	161	211	261	311	361	411	461	511	561	611	661	711	761	811	861	911	961	1011	1061	1111	1161	1211	1261	1311	1361	1411	1461	1511	1561	1611	1661	1711	1761	1811
G	1	1	1	2	2	2	2	3	3	3	3	4	4	4	4	5	5	5	5	6	6	6	6	7	7	7	7	8	8	8	8	8	8	8	
H	6	6	6	8	8	8	8	10	10	10	10	12	12	12	12	14	14	14	14	16	16	16	16	18	18	18	18	20	20	20	20	20	20	20	
J	341	391	441	491	541	591	641	691	741	791	841	891	941	991	1041	1091	1141	1191	1241	1291	1341	1391	1441	1491	1541	1591	1641	1691	1741	1791	1841	1841	1841	1841	
K	311	361	411	461	511	561	611	661	711	761	811	861	911	961	1011	1061	1111	1161	1211	1261	1311	1361	1411	1461	1511	1561	1611	1661	1711	1761	1811	1811	1811	1811	

Stroke	1750	1800	1850	1900	1950	2000	2050	2100	2150	2200	2250	2300	2350	2400	2450	2500	2550	2600	2650	2700	2750	2800	2850	2900	2950	3000	3050	3100	3150	3200						
L	2299.5	2349.5	2399.5	2449.5	2499.5	2549.5	2599.5	2649.5	2699.5	2749.5	2799.5	2849.5	2899.5	2949.5	2999.5	3049.5	3099.5	3149.5	3199.5	3249.5	3299.5	3349.5	3399.5	3449.5	3499.5	3549.5	3599.5	3649.5	3699.5	3749.5	3749.5	3749.5	3749.5			
B	2098	2148	2198	2248	2298	2348	2398	2448	2498	2548	2598	2648	2698	2748	2798	2848	2898	2948	2998	3048	3098	3148	3198	3248	3298	3348	3398	3448	3498	3548	3548	3548	3548	3548		
F	61	111	161	211	261	311	361	411	461	511	561	611	661	711	761	811	861	911	961	1011	1061	1111	1161	1211	1261	1311	1361	1411	1461	1511	1561	1611	1661	1711	1761	1811
G	9	9	9	9	10	10	10	10	10	11	11	11	11	12	12	12	12	13	13	13	13	14	14	14	14	15	15	15	15	16	16	16	16	16	16	16
H	22	22	22	22	24	24	24	24	24	26	26	26	26	28	28	28	28	30	30	30	30	32	32	32	32	34	34	34	34	34	34	34	34	34	34	34
J	1891	1941	1991	2041	2091	2141	2191	2241	2291	2341	2391	2441	2491	2541	2591	2641	2691	2741	2791	2841	2891	2941	2991	3041	3091	3141	3191	3241	3291	3341	3341	3341	3341	3341	3341	
K	1861	1911	1961	2011	2061	2111	2161	2211	2261	2311	2361	2411	2461	2511	2561	2611	2661	2711	2761	2811	2861	2911	2961	3011	3061	3111	3161	3211	3261	3311	3311	3311	3311	3311	3311	3311

■ Mass by Stroke

Stroke	200	250	300	350	400	450	500	550	600	650	700	750	800	850	900	950	1000	1050	1100	1150	1200	1250	1300	1350	1400	1450	1500	1550	1600	1650	1700			
Mass (kg)	11.2	11.7	12.2	12.7	13.2	13.8	14.3	14.8	15.3	15.8	16.3	16.8	17.3	17.9	18.4	18.9	19.4	19.9	20.4	20.9	21.4	22.0	22.5	23.0	23.5	24.0	24.5	25.0	25.5	26.1	26.6	26.6	26.6	26.6

Stroke	1750	1800	1850	1900	1950	2000	2050	2100	2150	2200	2250	2300	2350	2400	2450	2500	2550	2600	2650	2700	2750	2800	2850	2900	2950	3000	3050	3100	3150	3200					
Mass (kg)	27.1	27.6	28.1	28.6	29.1	29.6	30.2	30.7	31.2	31.7	32.2	32.7	33.2	33.7	34.2	34.8	35.3	35.8	36.3	36.8	37.3	37.8	38.3	38.9	39.4	39.9	40.4	40.9	41.4	41.9	41.9	41.9	41.9	41.9	41.9

IFA-MA3 (downward facing motor)

(Note) Connect the motor cable and encoder cable to the cable joint connector. Please refer to P. 30 for cable details.
 (Note) When the slider is returning to its home position, be careful of interference from surrounding objects, as it will travel until it reaches the M.E.
 (Note) Be aware that the product must be returned to IAI in order to change the home direction.
 (Note) The figure below shows MA3L.

ST: Stroke
 M.E: Mechanical end
 S.E: Stroke end

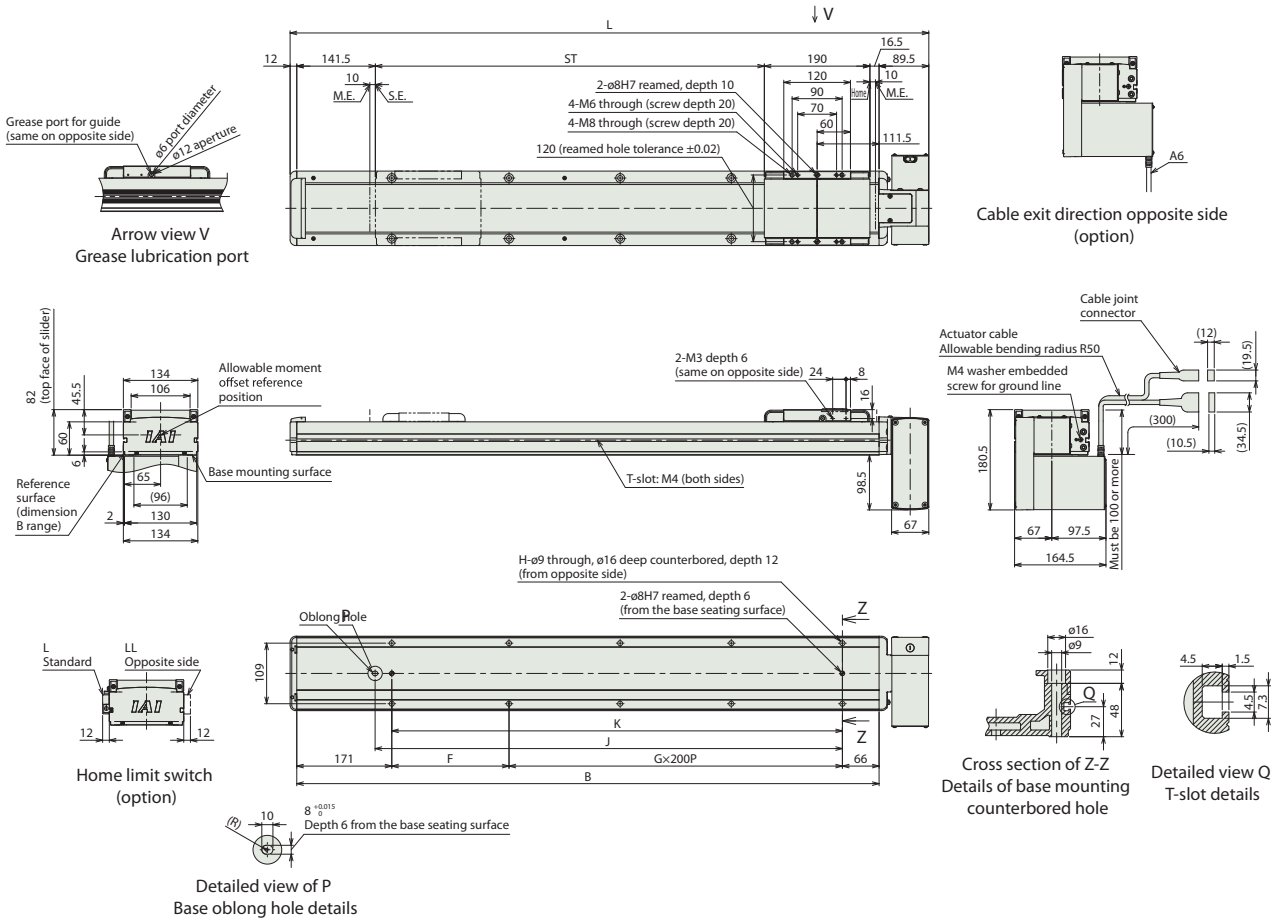

Dimensions by Stroke

Stroke	200	250	300	350	400	450	500	550	600	650	700	750	800	850	900	950	1000	1050	1100	1150	1200	1250	1300	1350	1400	1450	1500	1550	1600	1650	1700
L	649.5	699.5	749.5	799.5	849.5	899.5	949.5	999.5	1049.5	1099.5	1149.5	1199.5	1249.5	1299.5	1349.5	1399.5	1449.5	1499.5	1549.5	1599.5	1649.5	1699.5	1749.5	1799.5	1849.5	1899.5	1949.5	1999.5	2049.5	2099.5	2149.5
B	548	598	648	698	748	798	848	898	948	998	1048	1098	1148	1198	1248	1298	1348	1398	1448	1498	1548	1598	1648	1698	1748	1798	1848	1898	1948	1998	2048
F	111	161	211	261	311	361	411	461	511	561	611	661	711	761	811	861	911	961	1011	1061	1111	1161	1211	1261	1311	1361	1411	1461	1511	1561	1611
G	1	1	1	2	2	2	2	3	3	3	3	4	4	4	4	5	5	5	5	6	6	6	6	7	7	7	7	8	8	8	8
H	6	6	6	8	8	8	8	10	10	10	10	12	12	12	12	14	14	14	14	16	16	16	16	18	18	18	18	20	20	20	20
J	341	391	441	491	541	591	641	691	741	791	841	891	941	991	1041	1091	1141	1191	1241	1291	1341	1391	1441	1491	1541	1591	1641	1691	1741	1791	1841
K	311	361	411	461	511	561	611	661	711	761	811	861	911	961	1011	1061	1111	1161	1211	1261	1311	1361	1411	1461	1511	1561	1611	1661	1711	1761	1811

Stroke	1750	1800	1850	1900	1950	2000	2050	2100	2150	2200	2250	2300	2350	2400	2450	2500	2550	2600	2650	2700	2750	2800	2850	2900	2950	3000	3050	3100	3150	3200	
L	2199.5	2249.5	2299.5	2349.5	2399.5	2449.5	2499.5	2549.5	2599.5	2649.5	2699.5	2749.5	2799.5	2849.5	2899.5	2949.5	2999.5	3049.5	3099.5	3149.5	3199.5	3249.5	3299.5	3349.5	3399.5	3449.5	3499.5	3549.5	3599.5	3649.5	
B	2098	2148	2198	2248	2298	2348	2398	2448	2498	2548	2598	2648	2698	2748	2798	2848	2898	2948	2998	3048	3098	3148	3198	3248	3298	3348	3398	3448	3498	3548	
F	61	111	161	211	261	311	361	411	461	511	561	611	661	711	761	811	861	911	961	1011	1061	1111	1161	1211	1261	1311	1361	1411	1461	1511	
G	9	9	9	9	10	10	10	10	11	11	11	11	12	12	12	13	13	13	13	14	14	14	14	15	15	15	15	16	16	16	16
H	22	22	22	22	24	24	24	24	26	26	26	26	28	28	28	28	30	30	30	30	32	32	32	32	34	34	34	34	36	36	36
J	1891	1941	1991	2041	2091	2141	2191	2241	2291	2341	2391	2441	2491	2541	2591	2641	2691	2741	2791	2841	2891	2941	2991	3041	3091	3141	3191	3241	3291	3341	
K	1861	1911	1961	2011	2061	2111	2161	2211	2261	2311	2361	2411	2461	2511	2561	2611	2661	2711	2761	2811	2861	2911	2961	3011	3061	3111	3161	3211	3261	3311	

Mass by Stroke

Stroke	200	250	300	350	400	450	500	550	600	650	700	750	800	850	900	950	1000	1050	1100	1150	1200	1250	1300	1350	1400	1450	1500	1550	1600	1650	1700
Mass (kg)	11.2	11.7	12.2	12.7	13.2	13.8	14.3	14.8	15.3	15.8	16.3	16.8	17.3	17.9	18.4	18.9	19.4	19.9	20.4	20.9	21.4	22.0	22.5	23.0	23.5	24.0	24.5	25.0	25.5	26.1	26.6

Stroke	1750	1800	1850	1900	1950	2000	2050	2100	2150	2200	2250	2300	2350	2400	2450	2500	2550	2600	2650	2700	2750	2800	2850	2900	2950	3000	3050	3100	3150	3200
Mass (kg)	27.1	27.6	28.1	28.6	29.1	29.6	30.2	30.7	31.2	31.7	32.2	32.7	33.2	33.7	34.2	34.8	35.3	35.8	36.3	36.8	37.3	37.8	38.3	38.9	39.4	39.9	40.4	40.9	41.4	41.9

Dimension for double slider specification

(Note) Connect the motor cable and encoder cable to the cable joint connector. Please refer to P. 30 for cable details.
 (Note) When the slider is returning to its home position, be careful of interference from surrounding objects, as it will travel until it reaches the M.E.
 (Note) Be aware that the product must be returned to IA! in order to change the home direction.
 (Note) The figure below shows MA1L.
 (Note) The figure below shows dimensions at minimum actual slider span.

CAD drawings can be downloaded from our website.
www.intelligentactor.de



ST: Stroke
 M.E: Mechanical end
 S.E: Stroke end

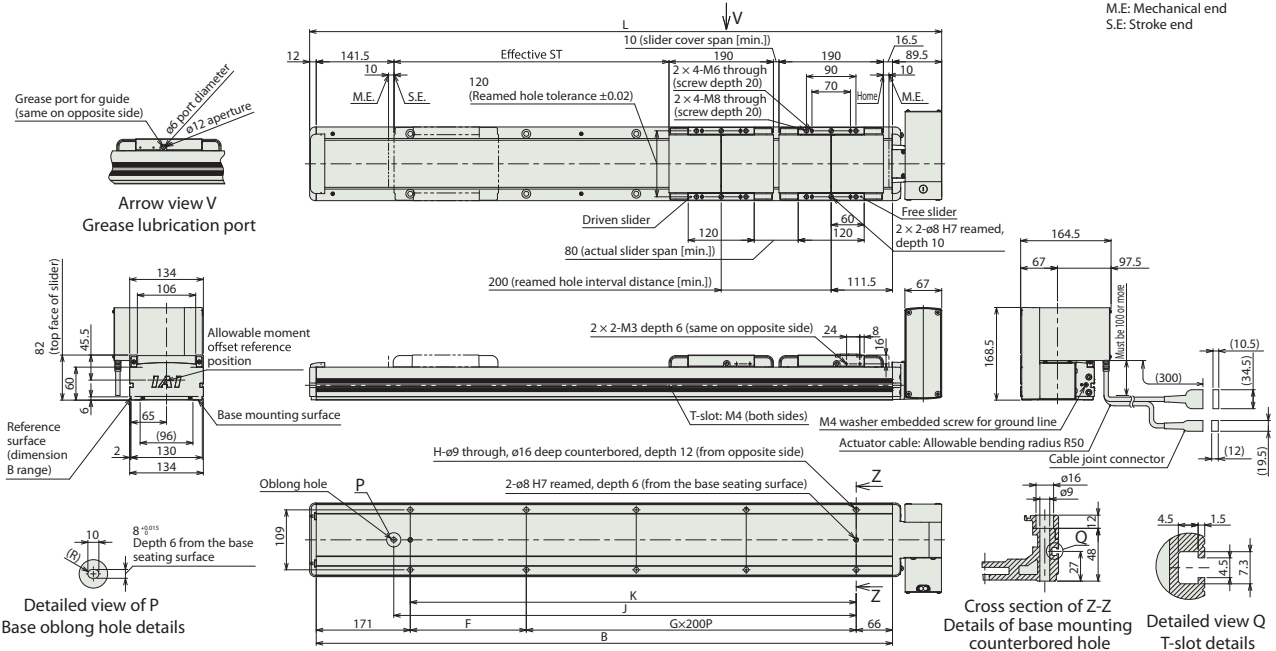

Dimensions by Stroke

Nominal stroke	400	450	500	550	600	650	700	750	800	850	900	950	1000	1050	1100	1150	1200	1250	1300	1350	1400	1450	1500	1550	1600	1650	1700	1750	1800
Effective stroke	200	250	300	350	400	450	500	550	600	650	700	750	800	850	900	950	1000	1050	1100	1150	1200	1250	1300	1350	1400	1450	1500	1550	1600
L	849.5	899.5	949.5	999.5	1049.5	1099.5	1149.5	1199.5	1249.5	1299.5	1349.5	1399.5	1449.5	1499.5	1549.5	1599.5	1649.5	1699.5	1749.5	1799.5	1849.5	1899.5	1949.5	1999.5	2049.5	2099.5	2149.5	2199.5	2249.5
B	748	798	848	898	948	998	1048	1098	1148	1198	1248	1298	1348	1398	1448	1498	1548	1598	1648	1698	1748	1798	1848	1898	1948	1998	2048	2098	2148
F	111	161	211	261	311	361	411	461	511	561	611	661	711	761	811	861	911	961	1011	1061	1111	1161	1211	1261	1311	1361	1411	1461	1511
G	2	2	2	3	3	3	3	4	4	4	4	5	5	5	5	6	6	6	6	6	7	7	7	8	8	8	8	9	9
H	8	8	8	10	10	10	10	12	12	12	12	14	14	14	14	16	16	16	16	16	18	18	18	20	20	20	20	22	22
J	541	591	641	691	741	791	841	891	941	991	1041	1091	1141	1191	1241	1291	1341	1391	1441	1491	1541	1591	1641	1691	1741	1791	1841	1891	1941
K	511	561	611	661	711	761	811	861	911	961	1011	1061	1111	1161	1211	1261	1311	1361	1411	1461	1511	1561	1611	1661	1711	1761	1811	1861	1911

Nominal stroke	1850	1900	1950	2000	2050	2100	2150	2200	2250	2300	2350	2400	2450	2500	2550	2600	2650	2700	2750	2800	2850	2900	2950	3000	3050	3100	3150	3200
Effective stroke	1650	1700	1750	1800	1850	1900	1950	2000	2050	2100	2150	2200	2250	2300	2350	2400	2450	2500	2550	2600	2650	2700	2750	2800	2850	2900	2950	3000
L	2299.5	2349.5	2399.5	2449.5	2499.5	2549.5	2599.5	2649.5	2699.5	2749.5	2799.5	2849.5	2899.5	2949.5	2999.5	3049.5	3099.5	3149.5	3199.5	3249.5	3299.5	3349.5	3399.5	3449.5	3499.5	3549.5	3599.5	3649.5
B	2198	2248	2298	2348	2398	2448	2498	2548	2598	2648	2698	2748	2798	2848	2898	2948	2998	3048	3098	3148	3198	3248	3298	3348	3398	3448	3498	3548
F	161	211	261	311	361	411	461	511	561	611	661	711	761	811	861	911	961	1011	1061	1111	1161	1211	1261	1311	1361	1411	1461	1511
G	9	9	10	10	10	10	11	11	11	11	12	12	12	12	13	13	13	13	14	14	14	15	15	15	15	15	16	16
H	22	22	24	24	24	24	26	26	26	26	28	28	28	28	30	30	30	30	32	32	32	34	34	34	34	34	36	36
J	1991	2041	2091	2141	2191	2241	2291	2341	2391	2441	2491	2541	2591	2641	2691	2741	2791	2841	2891	2941	2991	3041	3091	3141	3191	3241	3291	3341
K	1961	2011	2061	2111	2161	2211	2261	2311	2361	2411	2461	2511	2561	2611	2661	2711	2761	2811	2861	2911	2961	3011	3061	3111	3161	3211	3261	3311

(Note) Nominal stroke: Stroke listed in the model name; effective stroke: actually operable stroke

Mass by Stroke

Nominal stroke	400	450	500	550	600	650	700	750	800	850	900	950	1000	1050	1100	1150	1200	1250	1300	1350	1400	1450	1500	1550	1600	1650	1700	1750	1800
Effective stroke	200	250	300	350	400	450	500	550	600	650	700	750	800	850	900	950	1000	1050	1100	1150	1200	1250	1300	1350	1400	1450	1500	1550	1600
Mass (kg)	14.7	15.3	15.8	16.3	16.8	17.3	17.8	18.3	18.8	19.4	19.9	20.4	20.9	21.4	21.9	22.4	22.9	23.5	24.0	24.5	25.0	25.5	26.0	26.5	27.0	27.6	28.1	28.6	29.1

Nominal stroke	1850	1900	1950	2000	2050	2100	2150	2200	2250	2300	2350	2400	2450	2500	2550	2600	2650	2700	2750	2800	2850	2900	2950	3000	3050	3100	3150	3200
Effective stroke	1650	1700	1750	1800	1850	1900	1950	2000	2050	2100	2150	2200	2250	2300	2350	2400	2450	2500	2550	2600	2650	2700	2750	2800	2850	2900	2950	3000
Mass (kg)	29.6	30.1	30.6	31.1	31.7	32.2	32.7	33.2	33.7	34.2	34.7	35.2	35.7	36.3	36.8	37.3	37.8	38.3	38.8	39.3	39.8	40.4	40.9	41.4	41.9	42.4	42.9	43.4

(Note) The above mass values are for double slider specification. It is the sum of single slider specification's mass and free slider's mass (1.5kg)

Applicable Controllers

The actuator on this page can be operated with the controllers below. Select a type suited to the application.

Name	External view	Max. number of connectable axes	Power supply voltage	Control method													Max. number of positioning points	Reference page		
				Positioner	Pulse-train	Program	Network option *													
				DV	CC	CIE	PR	CN	ML	ML3	EC	EP	PRT	SSN	ECM					
RCON		16	DC24V Single phase 230VAC Three-phase 230VAC	—	—	—	●	●	●	●	—	—	—	●	●	●	—	●	128	Please see the dedicated catalog or manual.
RSEL		8		—	—	●	●	●	●	—	—	—	—	●	●	●	—	—	36000	
SCON-CB/CGB		1	Single phase AC 115V/230V	●	●	—	●	●	●	—	—	—	—	●	●	●	—	—	512 (768 for network specification)	
SSEL-CS		2		●	—	●	●	●	—	—	—	—	—	—	—	—	—	—	20000	
XSEL-P/Q		6	Single phase 230VAC	—	—	●	●	●	—	—	—	—	—	—	●	●	—	—	20000	
XSEL-RA/SA		8	Three-phase 230VAC	—	—	●	●	●	●	—	—	—	—	—	●	●	—	—	55000 (varies by type)	











* Network abbreviations: DV - DeviceNet | CC - CC-Link | CIE - CC-Link IE | PR - Profibus-DP | CN - CompoNet | ML - Mechatrolink | ML3 - Mechatrolink-III | EC - EtherCAT | EP - Ethernet/IP | PRT - Profinet-IO | SSN - SSCNET III/H | ECM - EtherCAT Motion

Options

Cable exit direction opposite side

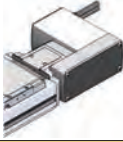
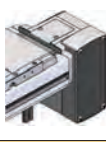
Model **A6**

Description This option switches the actuator cable exit direction to the opposite side.

Type	SA1L/MA1L	SA2L/MA2L	SA3L/MA3L	SA1R/MA1R	SA2R/MA2R	SA3R/MA3R
Standard						
A6						

AQ seal

Model **AQ** (equipped as standard)

Description This option is a lubricating unit which supplies large quantities of lubricating oil from a multiporous substance. Contact among the steel balls in the guide provides a continuous supply of lubricating oil, enabling long-term maintenance-free use thanks to the interaction with grease.

Ceiling/side mounting specifications

Model **CSM**

Description Be sure to select this option when using ceiling and side installation. During operation, a sound like the stainless steel sheet being struck may be audible. This is caused by the vibration of the belt during slider acceleration/deceleration, when the belt and stainless steel sheet make contact. It is not a functional issue, but should it become a problem, readjust the slider belt/drive belt tension or decrease the acceleration/deceleration speed in use.

Hanging fixture

Model **EB**

Description Eyebolts, mounting brackets, hex bolts, and hex nuts are included for suspending the actuator during installation. The coupling nuts used to fix the mounting bracket are shipped embedded in the T-slots on the body sides. *Please refer to the instruction manual for details.

Home limit switch

Model **L** (standard) **LL** (opposite side)

Description Normal home return motion uses the "push method" in which the slider is pushed against the mechanical end stopper and then returns, detecting the Z-phase as home. This option triggers the return motion with a proximity sensor. When specifying this option, three proximity sensors are mounted (HOME: home detection, +OT: non-motor side overtravel, and -OT: motor side overtravel). (HOME and -OT are integrated twin sensors.) Use for fine adjustment of the return position or to enhance dependability. (Note that if the home sensor is significantly moved, the stroke may be shortened.) The home limit switch and cover mounting positions are on the right side of the actuator body (viewed from the motor side) as standard (model: L). To install the sensors on the opposite side, select LL (mounting position opposite side).

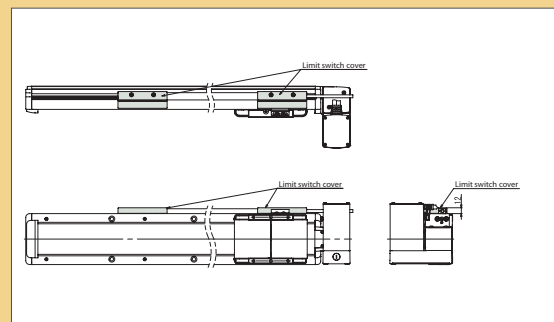

Non-motor end specification

Model **NM**

Description The home position is normally set to the motor side. This option is for setting the home position on the other side in order to accommodate variations in equipment layout, etc. (Because the home position is adjusted to the factory default for shipping, when changing home direction after delivery the product may need to be returned to IAI for adjustment.)

Double slider specification

Model **W**

Description This option adds a free slider on the drive belt motor side. Doubling the slider enables increased allowable moment and overhang load length. At shipping, the driven slider and free slider are not coupled. They are to be coupled by the customer for use.

Round cable joint connector with screw locking (EU standard)

Model **EU**

Description Option for a motor/encoder cable with round plastic/metal cable plug with screw locking. Without this option flat plastic plugs are default.

Double Slider Specification

■ Precautions for Double Slider Specification

(1) The dynamic allowable moment and overhang load length change depending on the span between the two sliders.

Dynamic allowable moment direction figure

These values for the dynamic allowable moment are based on the standard rated operation life. Note that use exceeding the moment specification value will shorten the guide life.

Moment direction

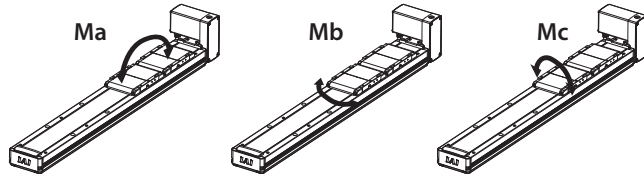

Overhang load length figure

Use exceeding the overhang allowable value may lead to vibration, so be sure to use within the allowable values.

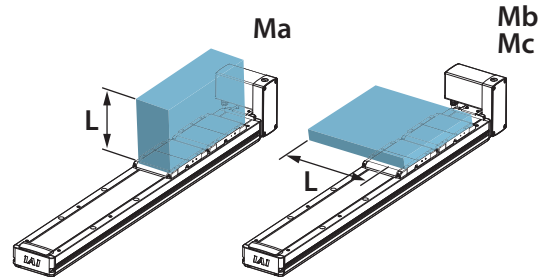

Double slider specification figure

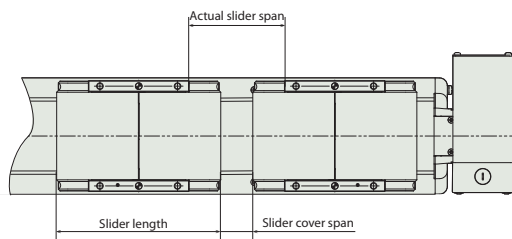

Slider coupling part (image)

At shipping, the driven slider and free slider are not coupled. They are to be coupled by the customer for use.

(Note) Be sure to couple the sliders at the slider span specified as of ordering.

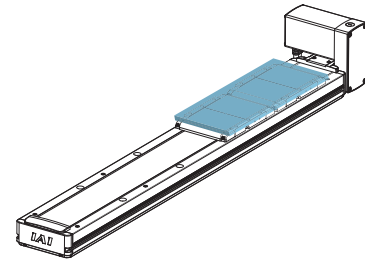

(2) Be sure to specify the effective stroke upon ordering.

Example IFA-SA1L-WA-100-1650-T2-M-AQ-W (Effective stroke: 1500mm)

(3) When specifying the double slider specification option, the effective stroke (actually operable stroke) is the length of the nominal stroke (stroke as in the model name) minus [Ⓐ] (slider length + slider cover span). When ordering, select a stroke length including the length plus [Ⓐ] or more as the required stroke. As well, make sure the effective stroke is at least the minimum effective stroke with double slider specification.

$$\text{Nominal stroke} \geq \text{Effective stroke} + \text{Ⓐ}$$

(stroke as in model name) (actually operable stroke)

Example IFA-SA

Effective stroke: 1500mm [Ⓐ]: 150mm (at actual slider span 60mm)

1500mm + 150mm = 1650mm -> Order at 1650mm or above in the model name

	Effective stroke available with double slider specification (mm)	[Ⓐ] Slider length + Slider cover span (mm)
200 ~ 2450 (nominal stroke 350 ~ 2600)	150	
220 ~ 2420 (nominal stroke 400 ~ 2600)	180	
200 ~ 3000 (nominal stroke 400 ~ 3200)	200	
210 ~ 2960 (nominal stroke 450 ~ 3200)	240	

(4) Be sure to confirm the payload with double slider specification in the Table of Payload by Speed/Acceleration (double slider specification) on the product specification pages.

■ Double slider specification table

Model	Dynamic allowable moment						Overhang load length (mm)	Slider mass (kg)	Slider length (mm)	Effective stroke available with double slider specification (mm)	[Ⓐ] Slider length + slider cover span (mm)	
	Standard rated operation life (km)	Slider span (mm)		Ma direction (N-m)	Mb direction (N-m)	Mc direction (N-m)						Ma/Mb/Mc direction
		Actual slider span	Slider cover span									
IFA-SA	10000	Min. 60	2	182	260	125	1200	0.7	148	200 ~ 2450 (nominal stroke 350 ~ 2600)	150	
		Max. 90	32	228	325	125	1350			220 ~ 2420 (nominal stroke 400 ~ 2600)	180	
IFA-MA	10000	Min. 80	10	448	640	307	1600	1.5	190	200 ~ 3000 (nominal stroke 400 ~ 3200)	200	
		Max. 120	50	561	801	307	1800			210 ~ 2960 (nominal stroke 450 ~ 3200)	240	

Duty Ratio

Estimated allowable duty ratio varies depending on operating conditions (payload and acceleration/deceleration). Using the formula below, calculate the load factor LF and acceleration/deceleration time ratio (tod) and find them in the graph.

! Caution: If an overload error occurs, increase the dwell time to lower the duty ratio or decrease the acceleration/deceleration.

[Duty ratio]
The duty ratio is the operating rate shown as the actuator's operating time during one cycle, expressed as a percentage.

$$D = \frac{T_M}{T_M + T_s} \times 100(\%)$$

D: Duty ratio
T_M: Operating time (including push-motion operation)
T_s: Stop time

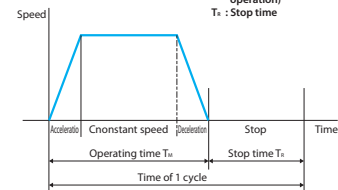

Calculating the duty ratio

Calculate the load factor and acceleration/deceleration time ratio, and read the duty ratio from the graph. When the load factor is less than 50%, operation with duty ratio of 100% (continuous operation) is possible.

1 Load factor (LF)

The IFA rated acceleration/deceleration is 0.3G. Please refer to the product specification page for the maximum payload at acceleration 0.3G.

When acceleration/deceleration during operation α is below 0.3G

$$\text{Load factor: LF} = \frac{M \times \alpha}{M_r \times 0.3} [\%]$$

Max. payload at rated acceleration : M_r [kg]

Payload during operation : M [kg]

Acceleration/deceleration during operation : α [G]

When acceleration/deceleration during operation α is above 0.3G

$$\text{Load factor: LF} = \frac{M \times \alpha}{M_d \times \alpha} = \frac{M}{M_d} [\%]$$

Command acceleration payload : M_d[kg]

Payload during operation : M [kg]

Acceleration/deceleration during operation : α [G]

2 Acceleration/deceleration time ratio tod

$$\text{Acceleration/deceleration time ratio tod} = \frac{\text{Acceleration time during operation} + \text{deceleration time during operation}}{\text{Operating time}} [\%]$$

$$\text{Acceleration time} = \frac{\text{Speed during operation} [\text{mm/s}]}{\text{Acceleration during operation} [\text{mm/s}^2]} [\text{sec.}]$$

$$\text{Deceleration time} = \frac{\text{Speed during operation} [\text{mm/s}]}{\text{Deceleration during operation} [\text{mm/s}^2]} [\text{sec.}]$$

$$\text{Acceleration} [\text{mm/s}^2] = \text{Acceleration (G)} \times 9800 \text{mm/s}^2$$

$$\text{Deceleration} [\text{mm/s}^2] = \text{Deceleration (G)} \times 9800 \text{mm/s}^2$$

3 From calculated load factor LF and acceleration/deceleration time ratio tod, read the duty ratio

Example: When load factor LF is 80% and acceleration/deceleration time ratio tod is 80%, the duty ratio guideline will be approximately 75%.

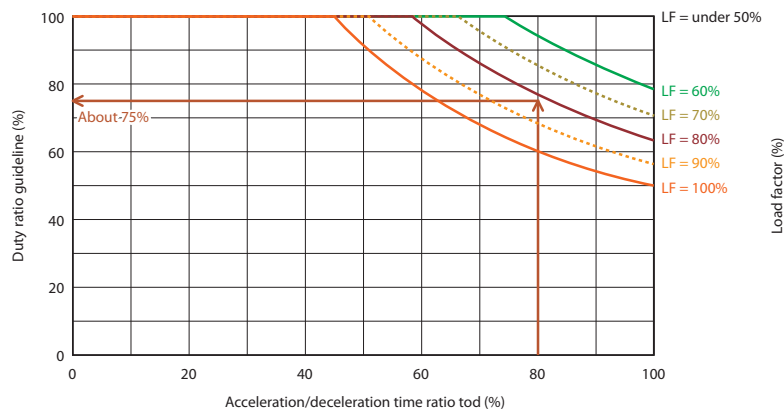

■ IFA maintenance part schematics

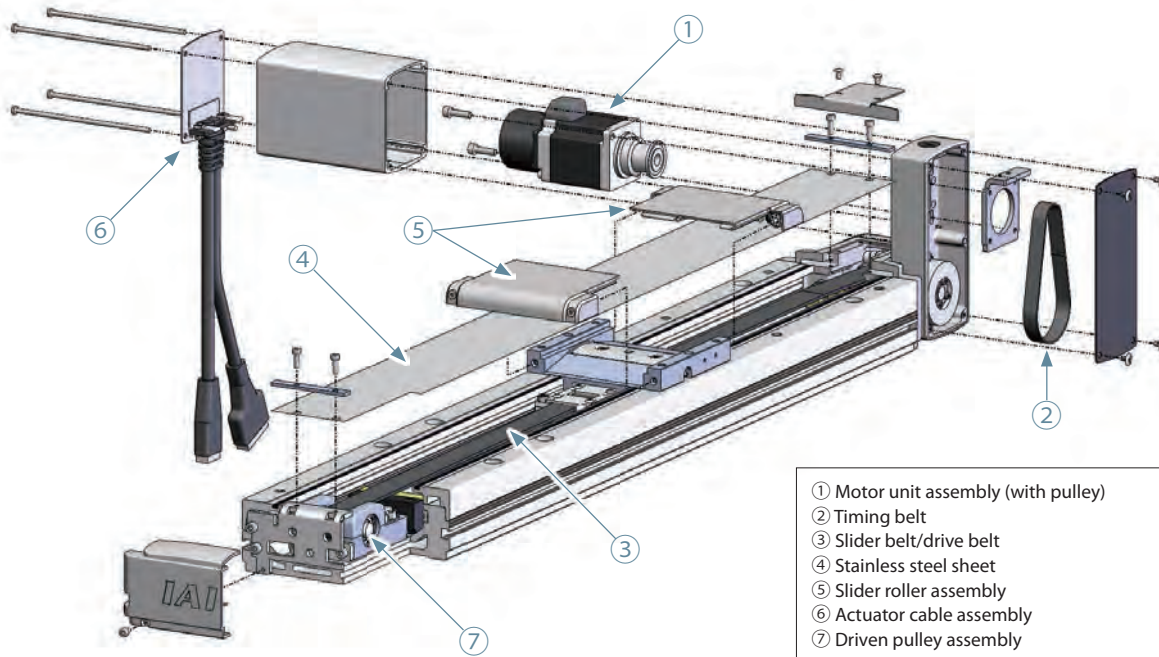

■ IFA maintenance part model list

The numbers in the table correspond to the numbers in the schematics.

① Motor unit assembly (with pulley)

Type	Motor wattage (W)	Model
SA	100	M-IFA-TMA100-WA-PU
MA	200	M-IFA-TMA200-WA-PU
	400	M-IFA-TMA400-WA-PU

⑤ Slider roller assembly

Type	Model
SA	SR-IFA-SA
MA	SR-IFA-MA

② Timing belt

Type	Model
SA	TB-IFA-SA
MA	TB-IFA-MA

⑥ Actuator cable assembly

Type	Model
SA	CB-IFA-SA-MPA-AS
MA	CB-IFA-MA-MPA-AS

③ Slider belt/drive belt

Type	Model
SA	LB-IFA-SA-○○○
MA	LB-IFA-MA-○○○

*○○○ indicates the stroke.

⑦ Driven pulley assembly

Type	Model
SA	PLY-IFA-SA
MA	PLY-IFA-MA

④ Stainless steel sheet

Type	Model	
	Single slider	Double-slider
SA	ST-IFA-SA-○○○	ST-IFA-SAD-○○○
MA	ST-IFA-MA-○○○	ST-IFA-MAD-○○○

*○○○ indicates the stroke in the model name.



Please refer to the IAI general catalogue extract, volume controller, for more information on controllers and options.

Single-axis controller

When controlling one axis with one controller

Supported control method
PIO (I/O)
Pulse-train
Field network
Serial communication (Modbus)

SCON



Pulse output is available for SCON. Convenient for linkage with related control devices.

(Inquire with IAI when using both field network control and pulse output)

- Low price
- The same control mode as the solenoid valve can be selected
- No dedicated controller program required

230v AC servo motor

Multi-axis controller

When controlling multiple axes with one controller

Supported control method
SEL language (IAI dedicated program)
PIO (I/O)
Field network

RCON



24v Pulse motor, 24v AC servo motor, 24v DC brushless motor, 230v AC servo motor

- Compact
- Low price
- Up to 16 connectable axes (some restrictions apply depending on operation mode)

RSEL



24v Pulse motor, 24v AC servo motor, 24v DC brushless motor, 230v AC servo motor

- Compact
- Low price
- Up to 8 connectable axes

SSEL



230v AC servo motor

- 2-axis synchronous control possible

XSEL



230v AC servo motor

- 2-axis synchronous control possible
- Interpolation with up to 8 axes possible

Use when conducting interpolation operation.

PC teaching software

Two types of software are available for setting position and parameters.



RCM-101-□

Supports controllers with "□CON" in the model name



IA-101-□

Supports controllers with "□SEL" in the model name

Teaching pendant



TB-02



TB-03

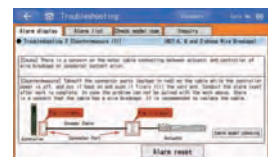

- Full-color touch panel equipped
- Enables position registration and test runs as well as error troubleshooting and maintenance part list confirmation

When placing an order for a replacement cable after purchasing a product, use the model name shown below.

Table of compatible cables

*Indicate the cable length (L) in □□□, maximum 30m
E.g.) 080 = 8m

	Motor robot cable		Encoder robot cable
	SCON/SSEL/XSEL	RCON/RSEL	Common to all controllers
IFA standard	CB-X-MA□□□□ / CB-XEU-MA□□□□	CB-X2-MA□□□□ / CB-XEU1-MA□□□□	CB-X1-PA□□□□ / CB-XEU1-PA□□□□
IFA with LS			CB-X1-PLA□□□□ / CB-XEU1-PLA□□□□

Model Name: **CB-X-MA□□□□ / CB-XEU-MA□□□□**

(Fig.: Motor robot cable CB-X-MA□□□□ with plastic connector)

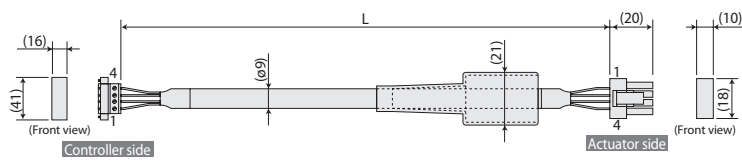

Minimum bending R: r = 51 mm or more (for movable use)

Wire	Color	Signal	No.	No.	Signal	Color	Wire
0.75sq	Green	PE	1	1	U	Red	0.75sq (crimped)
	Red	U	2	2	V	White	
	White	V	3	3	W	Black	
	Black	W	4	4	PE	Green	

(Fig.: EU motor robot cable CB-XEU-MA□□□□, EU version with M18 plastic round connector)

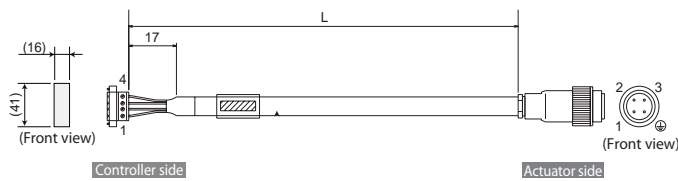

Minimum bending R: r = 51 mm or more (for movable use)

Wire	Color	Signal	No.	No.	Signal	Color	Wire
0.75sq	Green/yellow	PE	1	⊕	PE	Green/yellow	0.75sq (crimped)
	Black/white*1	U	2	1	U	Black/white*1	
	Black/white*2	V	3	2	V	Black/white*2	
	Black/white*3	W	4	3	W	Black/white*3	

Model Name: **CB-X2-MA□□□□ / CB-XEU1-MA□□□□**

(Fig.: Motor robot cable CB-X2-MA□□□□ with plastic connector)

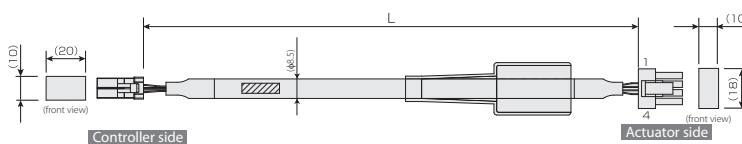

Minimum bending radius r = 51mm or more (for movable use)

Wiring	Color	Signal	No.	No.	Signal	Color	Wiring
0.75sq (crimped)	Red	U	B1	1	U	Red	0.75sq (crimped)
	White	V	B2	2	V	White	
	Black	W	A1	3	W	Black	
	Green	PE	A2	4	PE	Green	

(Fig.: EU motor robot cable CB-XEU1-MA□□□□, EU version with M18 plastic round connector)

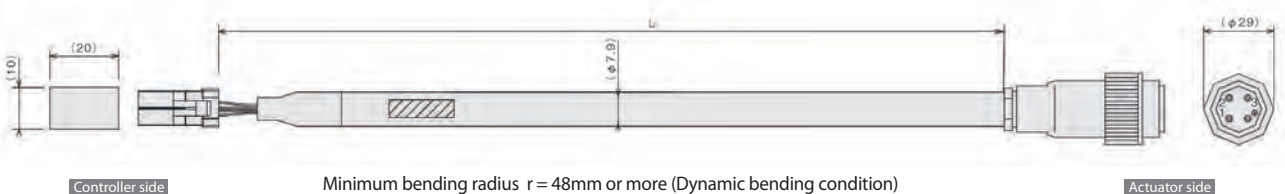

Minimum bending radius r = 48mm or more (Dynamic bending condition)

Wiring	Color	Signal	No.	No.	Signal	Color	Wiring
0.75sq (crimped)	1 with white character in black	U	B1	1	U	1 with white character in black	0.75sq (crimped)
	2 with white character in black	V	B2	2	V	2 with white character in black	
	3 with white character in black	W	A1	3	W	3 with white character in black	
	Green/yellow	PE	A2	⊕	PE	Green/yellow	

Maintenance Parts (Cables)

Model Name: **CB-X1-PA**□□□ / **CB-XEU1-PA**□□□

* Please indicate the cable length (L) in □□□, e.g) 080 = 8m maximum 20m

(Fig.: Encoder robot cable CB-X1-PA□□□ with plastic connector)

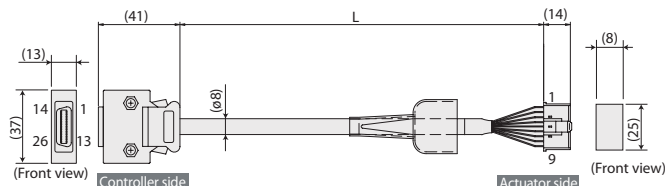

Minimum bend radius R: r = 44mm or larger (for movable use)

(Fig.: EU encoder robot cable CB-XEU1-PA□□□, EU version with metal round connector)

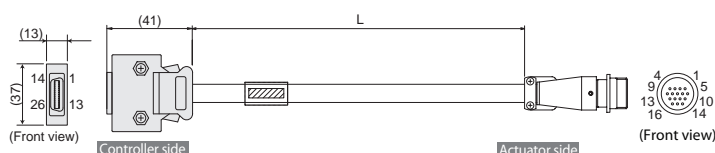

Minimum bend radius R: r = 44mm or larger (for movable use)

Wire	Color	Signal	No.
—	—	—	10
—	—	—	11
—	—	E24V	12
—	—	OV	13
—	—	LS	26
—	—	CREEP	25
—	—	OT	24
—	—	RSV	23
—	—	—	9
—	—	—	18
—	—	—	19
—	—	A+	1
—	—	A-	2
—	—	B+	3
—	—	B-	4
—	—	Z+	5
—	—	Z-	6
Orange	SRD+	7	7
Green	SRD-	8	8
Purple	BAT+	14	14
Gray	BAT-	15	15
Red	VCC	16	16
Black	GND	17	17
Blue	BKR-	20	20
Yellow	BKR+	21	21
—	—	—	22

No.	Signal	Color	Wire
1	BAT+	Purple	AWG26 (crimped)
2	BAT-	Gray	
3	SD	Orange	
4	SD	Green	
5	VCC	Red	
6	GND	Black	
7	FG	Ground	
8	BK-	Blue	
9	BK+	Yellow	

The shield is clamped to the hood
Braided ground & shield wire

Wire	Color	Signal	No.
—	—	—	10
—	—	—	11
—	—	E24V	12
—	—	OV	13
—	—	LS	26
—	—	CREEP	25
—	—	OT	24
—	—	RSV	23
—	—	—	9
—	—	—	18
—	—	—	19
—	—	A+	1
—	—	A-	2
—	—	B+	3
—	—	B-	4
—	—	Z+	5
—	—	Z-	6
Orange	SRD+	7	7
Green	SRD-	8	8
Purple	BAT+	14	14
Gray	BAT-	15	15
Red	VCC	16	16
Black	GND	17	17
Blue	BKR-	20	20
Yellow	BKR+	21	21
—	—	—	22

No.	Signal	Color	Wire
1	SD	Orange	AWG26 soldered
2	SD	Green	
3	—	—	
4	—	—	
5	—	—	
6	—	—	
7	—	—	
8	—	—	
9	—	—	
10	VCC	Red	
11	GND	Black	
12	BAT+	Purple	
13	BAT-	Gray	
14	—	—	
15	BK-	Blue	
16	BK+	Yellow	

The shield is clamped to the hood
Ground wire and braided shield

Model Name: **CB-X1-PLA**□□□ / **CB-XEU1-PLA**□□□

(Fig.: LS encoder robot cable CB-X1-PLA□□□ with plastic connector)

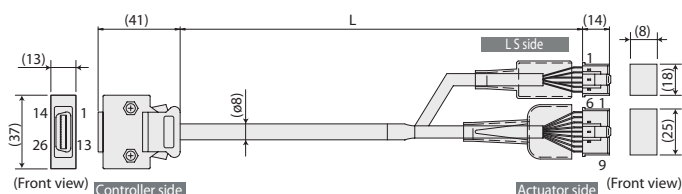

Minimum bend. radius R: r = 54mm or larger (for movable use)

Wire	Color	Signal	No.
—	—	—	10
—	—	—	11
White/Blue	E24V	12	12
White/Yellow	OV	13	13
White/Red	LS	26	26
White/Black	CREEP	25	25
White/Purple	OT	24	24
White/Gray	RSV	23	23
—	—	—	9
—	—	—	18
—	—	—	19
—	—	A+	1
—	—	A-	2
—	—	B+	3
—	—	B-	4
—	—	Z+	5
—	—	Z-	6
Orange	SRD+	7	7
Green	SRD-	8	8
Purple	BAT+	14	14
Gray	BAT-	15	15
Red	VCC	16	16
Black	GND	17	17
Blue	BKR-	20	20
Yellow	BKR+	21	21
—	—	—	22

No.	Signal	Color	Wire
1	BAT+	Purple	AWG26 (crimped)
2	OV	White/Yellow	
3	LS	White/Red	
4	CREEP	White/Black	
5	OT	White/Purple	
6	RSV	White/Gray	

No.	Signal	Color	Wire
1	BAT+	Purple	AWG26 (crimped)
2	BAT-	Gray	
3	SD	Orange	
4	SD	Green	
5	VCC	Red	
6	GND	Black	
7	FG	Ground	
8	BK-	Blue	
9	BK+	Yellow	

The shield is clamped to the hood
Braided ground & shield wire
(*White/Blue in cable color indicates the colors of line/insulator.)*

(Fig.: EU LS encoder robot cable CB-XEU1-PLA□□□, EU version with metal round connector)

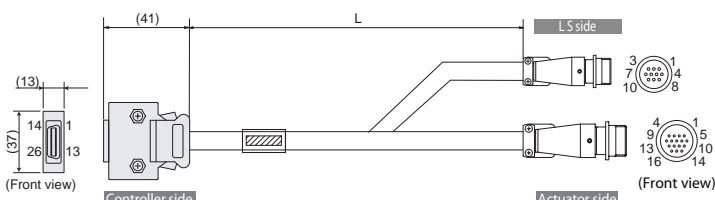

Minimum bend. radius R: r = 54mm or larger (for movable use)

Wire	Color	Signal	No.
—	—	—	10
—	—	—	11
White/Blue	E24V	12	12
White/Yellow	OV	13	13
White/Red	LS	26	26
White/Black	CREEP	25	25
White/Purple	OT	24	24
White/Gray	RSV	23	23
—	—	—	9
—	—	—	18
—	—	—	19
—	—	A+	1
—	—	A-	2
—	—	B+	3
—	—	B-	4
—	—	Z+	5
—	—	Z-	6
Orange	SRD+	7	7
Green	SRD-	8	8
Purple	BAT+	14	14
Gray	BAT-	15	15
Red	VCC	16	16
Black	GND	17	17
Blue	BKR-	20	20
Yellow	BKR+	21	21
—	—	—	22

No.	Signal	Color	Wire
1	E24V	White/Blue	AWG26 soldered
2	OV	White/Yellow	
3	—	—	
4	LS	White/Red	
5	CREEP	White/Black	
6	OT	White/Purple	
7	RSV	White/Gray	
8/9/10	—	—	

No.	Signal	Color	Wire
1	SD	Orange	AWG26 soldered
2	SD	Green	
3	—	—	
4	—	—	
5	—	—	
6	—	—	
7	—	—	
8	—	—	
9	—	—	
10	VCC	Red	
11	GND	Black	
12	BAT+	Purple	
13	BAT-	Gray	
14	—	—	
15	BK-	Blue	
16	BK+	Yellow	

The shield is clamped to the hood
Ground wire and braided shield
(*White/Blue in cable color indicates the colors of line/insulator.)*